



labtone 莱伯通

Focus On Mechanical Environmental Testing Equipment 专注于力学环境试验设备

Electro-dynamic Vibration Testing System

EV206H0808 VCSusb-2



Email: info@labtone.cn

Contents

- I. Product Application
- II. Type Selection Formula of Vibrator and Structural Diagram of Vibration Generator
- III. Principle Block Diagram of Equipment
- IV. Equipment Composition
- V. Technical Parameters
- VI. Introduction to Equipment Performance
- VII. Introduction to digital vibration controller
- VIII. Equipment Pictures



The technical proposal for your company is as follows:

I. Product Application

Vibration test is a process of exciting or shocking some part or device to observe its reaction in real environment. Vibration test is widely applied in many fields, ranging from circuit board, airplane, ship, rocket, missile, automobile, household appliance and other industrial products.

Labtone can offer you the whole vibration and testing proposal, and provide you with the quality certificates of products according to national and international standards, including GB, GJB, UL, JIS, DIN, ISO, BS, MIL, IEC and ASTM standards.

II. Type Selection Formula of Vibrator and Structural Diagram of Vibration Generator

- ① Test conditions provided by your company;
- ② Test types: sine sweep; random;
- ③ Frequency response range: 2 to 3000Hz
- ④ Formula: $A(g) = (2\pi f)^2 D_{cm} / 980 \approx A = 0.002 D_{mm} F^2$ $D = A / 0.002 F^2$
 $F = M(kg) \times A(g)$

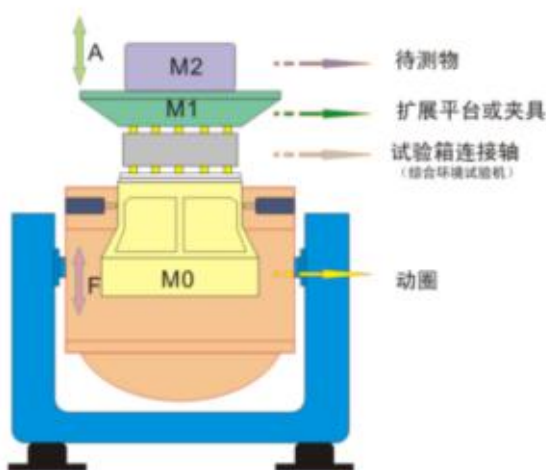

$$F = (M_0 + M_1 + M_2) \times A \times 1.3$$

Sine Force (p-p) 正弦推力

F: Exciting Force(kgf) 激振力

M0: Armature mass(kg) 动圈重量

M1: Auxiliary table or Fixture(kg) 平台或夹具重量

M2: Specimen (kg) 待测物件重量

A: 加速度 $g(m/s^2)$

1.3: Safety Factor(安全系数)

Random Force(Rms) 随机推力

= Sine Force $/\sqrt{2}$ 正弦推力 / 1.4

Shock Force 冲击推力

= Sine Force * 2 正弦推力 * 2

注：当采用重力为单位时，加速度单位为g，激振力单位为kgf 其中1g=9.8m/s²

III. Principle Block Diagram of Equipment

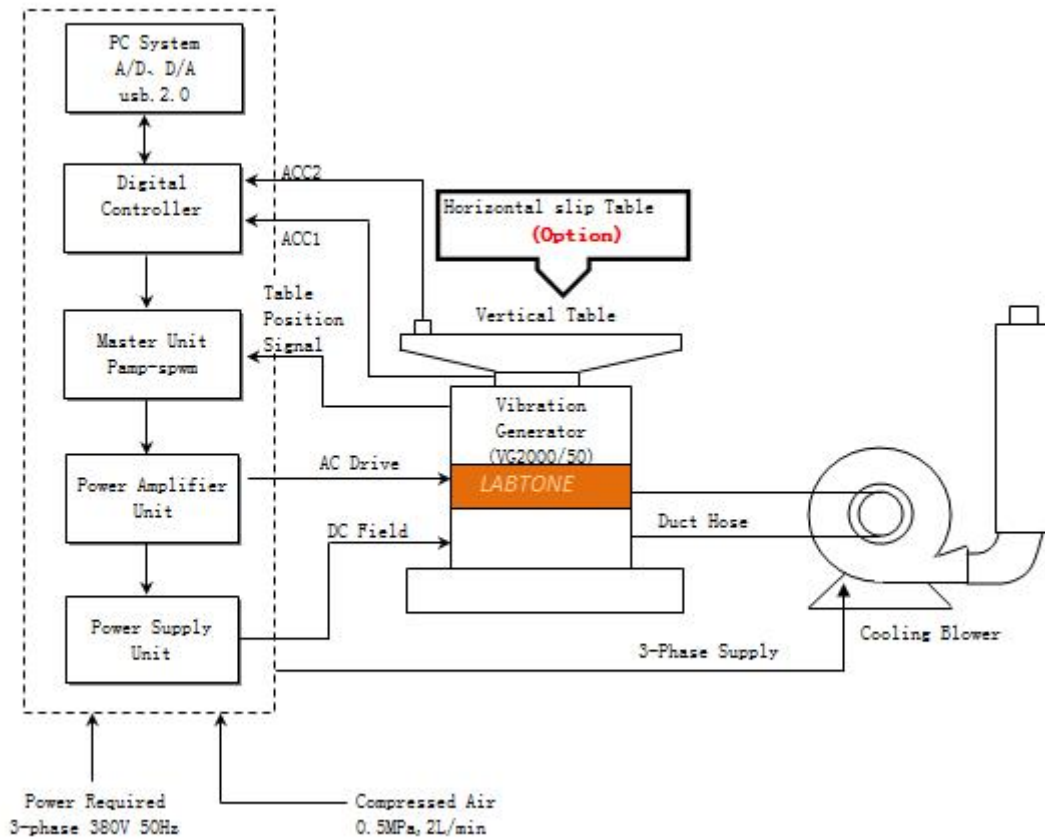

Installation diagram of vibration tester

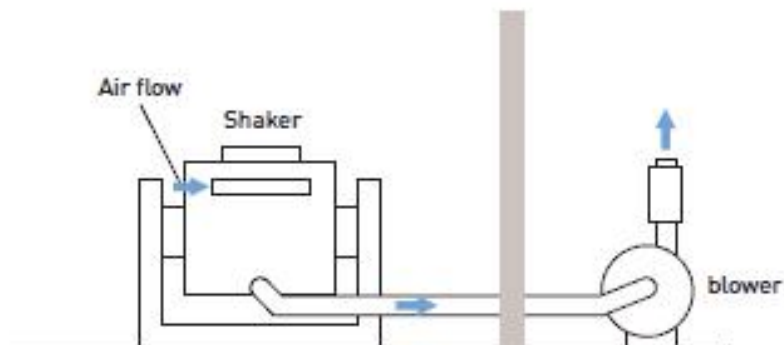

IV. Equipment Configuration

Item	Configuration	Qty.
1.	Shaker	
	VG600-50 electromagnetic vibration generator	1 set
	BL-600 cooling blower (including silencer)	1 set
	VT680 vertical extending table	1 set
	H0808 horizontal slip table	1 set
	Automatic centering system of armature	1 set
2.	Digital switch power amplifier	
	Amp6k digital switch power amplifier	1 set
	Servo protection system	1 set
	Excitation power supply	1 set
3.	Digital vibration controller (integrated instrument cabinet)	
	Master unit of digital vibration controller	1 set
	System acceleration sensor	1 pcs
	Control computer	1 set
	Control software installation disc	1 set
4.	Attached accessories	
	Extension cable and duct hose	1 set
	Operation instructions, inspection report, certificate, maintenance manual, etc.	1 set
	Attached special tools	1 set
	Vibration press rod / strip fixture	1 set

V. Technical Parameters

Parameters of VG600-50 electromagnetic vibration generator			
Max. sine exciting force	600Kg.f peak (6kN)		
Max. random exciting force	600Kg.f r.ms (6kN)		
Max. shock exciting force	1200Kg.f peak (12kN)		
Frequency range	1 - 3000 Hz		
Max. displacement	50.8 mm p-p		
Max. velocity	2m/s		
Max. acceleration	100G (980 m/s ²)		
Max. load (sine) F=M.A			
5G (49 m/s²)	10G (98 m/s²)	20G (196 m/s²)	30G (294 m/s²)
114kg	54kg	24kg	14kg
First-order resonance frequency	3200 Hz±5%		
Effective load	200 kg		
Vibration isolation frequency	2.5 Hz		
Diameter of armature	Φ200 mm		
Mass of armature	6kg		
Table screw	16×M8		
Flux leakage	< 10gauss		
Allowable eccentric moment	300N.m		
Shaker dimension	890 × 750 × 850 mm		
Shaker weight	About 920Kg		
Amp-6K digital switch power amplifier			
Output power	6KVA		
Output voltage	100V		
Output current	60A		
Amplifier efficiency	≥90%		
Switching frequency	116KHz		
Signal to noise ratio	≥65dB		
Noise	≤70dB		
Amplifier dimension	880 × 590 × 1275 mm		
Servo protection system			
Functions:	Temperature, air pressure, over-displacement, over-voltage, over-current, input under-voltage, external fault, control power supply, logic fault, input phase loss, etc.		
Digital vibration controller VCS-2			
Hardware configuration:	2-channels input, 1-channel output		
Control computer	1 set		
Software	Chinese / English instructions are provided, and the software is available for time-domain and frequency-domain analysis, signal		

	source and sine frequency sweep analysis, etc. It also can automatically generate WORD test report, display and store signal and data, and set testing parameters and analysis function.
Function	Sine, random
Acceleration sensor LAB	Frequency range: 0.3 to 7000Hz Sensitivity: 30pC/g Temperature range: -40℃ to 160℃
VT680 Vertical extending table	
Material	Aluminum alloy with surface hard anodized
Dimension	800 ×800 mm
Fixing hole	M8 durable and wear-resistant stainless steel screw sleeve
Frequency of use	500Hz
Weight	60KG
H0808 Horizontal slip table	
Material	Aluminum alloy with surface hard anodized
Dimension	800 ×800 mm
Fixing hole	M8 durable and wear-resistant stainless steel screw sleeve
Frequency of use	2000Hz
Weight	80KG
BL-600 cooling blower (including silencer)	
Blower power:	4KW
Flow rate	22m ³ /Min
Electrical requirements:	
Power supply	AC three-phase 380V/50Hz
Compressed air	0.6Mpa
Ground resistance	≤4Ω

VI. Introduction to Equipment Performance

6.1 Vibration table VG600-50

6.1.1 Armature

Vibration table is provided with cast and manually processed armature, photoelectric pneumatic load support system and dual-bearing axial guide. The dual-bearing guide has a special function. It has excellent durability and can reduce axial dynamic crossing and rotation in vibration test process.

6.1.2 Excitation coil

It is of double magnetic circuit structure with low flux leakage and uniform magnetic field.

6.1.3 Table surface

Advanced phosphating and automotive paint technologies are applied for the surface to resist wear and rusting for long time.

6.1.4 Table cooling

Intake air structure with low noise blower and improved table is applied, the excitation coil is of cellular duct, middle magnetic loop is of double-layer split duct, so new duct design is applied to enhance cooling effect.

6.2 SA digital switch power amplifier

MOSFET or IGBT technology with reliable performance is used for SA digital switch power amplifier.

- a. High stability and reliability.
- b. Consistency with "CE" standard requirements of EU.
- c. The power amplifier has high signal to noise ratio as sine double-frequency pulse width modulation technology is used.
- d. Switching efficiency is high as operating principle of the switching power supply is used.
- e. Automatic electronic current sharing technology is used.
- f. Good safety.

6.3 Servo protection system

It has complete protection functions, including grid overvoltage, under-voltage, phase loss, logic fault, power module conduction through, over-temperature, over-current output, overvoltage output, power supply drive, table over-displacement, table temperature, external interlocking, etc.

6.4 Vertical extending platform

The extending platform is usually used as a large installation platform of specimens which can be square, round or defined by users. In order to reduce dynamic impact on the extending platform, all extending platforms must be subject to analysis of modal frequency by modeling, and these platforms are generally made of magnesium alloy and attached with damping materials.

6.5 Automatic photoelectric centering system

It automatically adjusts position of the armature to keep it in balance state. The automatic centering system is used to ensure that the armature is in the center during loading and unloading process.

6.6 Horizontal oil film slip table

The horizontal slip table is designed to have high tilting moment and lateral restriction. This design concept is combined with standard horizontal slip table to enable high dynamic moment limit and keep guide oil film damping feature. The horizontal slip table is composed of a slipper, a connector, a natural granite slab, horizontal slip table base and an independent oil source.



VII. Introduction to digital vibration controller

The vibration controller is of advanced distribution structure system, and closed-loop control is achieved by DSP processor. PC is independent of control loop to ensure real-time and high efficiency of the control system so as to timely and rapidly respond to any changes of the test system, and ensure control stability and high precision. 32-bit floating-point DSP processor with primary frequency up to 300MHz and 24-bit resolution ADC/DAC are used for hardware in coordination with high precision floating-point digital filtering and low noise design technology of hardware circuit. The dynamic random control range of the controller is more than 90dB and the signal to noise ratio is more than 100dB.

7.1 Features of vibration controller

a. High performance and reliability

Closed-loop control is achieved by DSP processor, PC is independent of control loop to ensure real-time and high efficiency of the control system so as to timely and rapidly respond to any changes of the test system, and ensure control stability and high precision. All input channels are provided with ADC with 24-bit resolution, low noise hardware design and built-in simulation and digital anti-alias filter to effectively ensure high precision of analysis.

b. Simple operation

[Email:info@labtone.cn](mailto:info@labtone.cn)

The application software based on Windows has convenient operation and many auxiliary functions. Complex and dull testing task can become simple by automatic guiding with strong system function and test report automatic generation functions of the system. Testing parameters are richly and seriously set, and the application software can be tightly and harmoniously connected with the computer by USB2.0 interface.

c. Strong function and flexibility

The vibration controller is of a vibration control platform with strong function and can complete many complex tasks. On the same hardware platform, different types of application software can be configured to complete many analysis tasks so as to meet your different testing and analysis requirements. The controller is subject to modular design. Corresponding hardware and software can be configured according to different users' requirements to meet different user demands.

d. Safety of test

Signal control at low magnitude can be provided by the controller so as to obtain preview of vibration control of the system. This method can help test engineers to predetermine noise level and roughly understand transfer function and other features of the system. Multiple safety inspections and interlocking can ensure safety of test operators, specimens and equipment on the vibration table to the utmost extent. Stop key built in the system can be immediately pressed to end the test in case of any abnormality of the system.

e. Generation of test report

It supports rapid generation of test report in word format or PDF format by pressing a key, and you only need to click report generation button to obtain current test results. It covers description of basic test control function and specific test setting parameters, and control target spectrum curve and curves of test time domain and frequency domain. Therefore, it helps you to modify and make the test report according to different test report specifications, directly print and preview report and send report on line.

7.2 Function description of digital vibration controller

Random control (Random)

According to the power spectrum chart defined by the user (prepared by the target spectrum editor), random control is performed by transfer function equilibrium method for continuously outputting Gaussian random signal, rapidly carrying out precision multi-channel closed-loop control in real time. The built-in self-adaptive control algorithm can rapidly respond to nonlinear, resonance frequency and load changes of the system.

Frequency range: 0 to 4800Hz, extendable to 18750Hz

Resolution: 100, 200, 400, 800, 1600, 3200 spectrum line

Dynamic control range: >90dB.

Control strategy: single-channel control, weighted mean, max. value and min. value

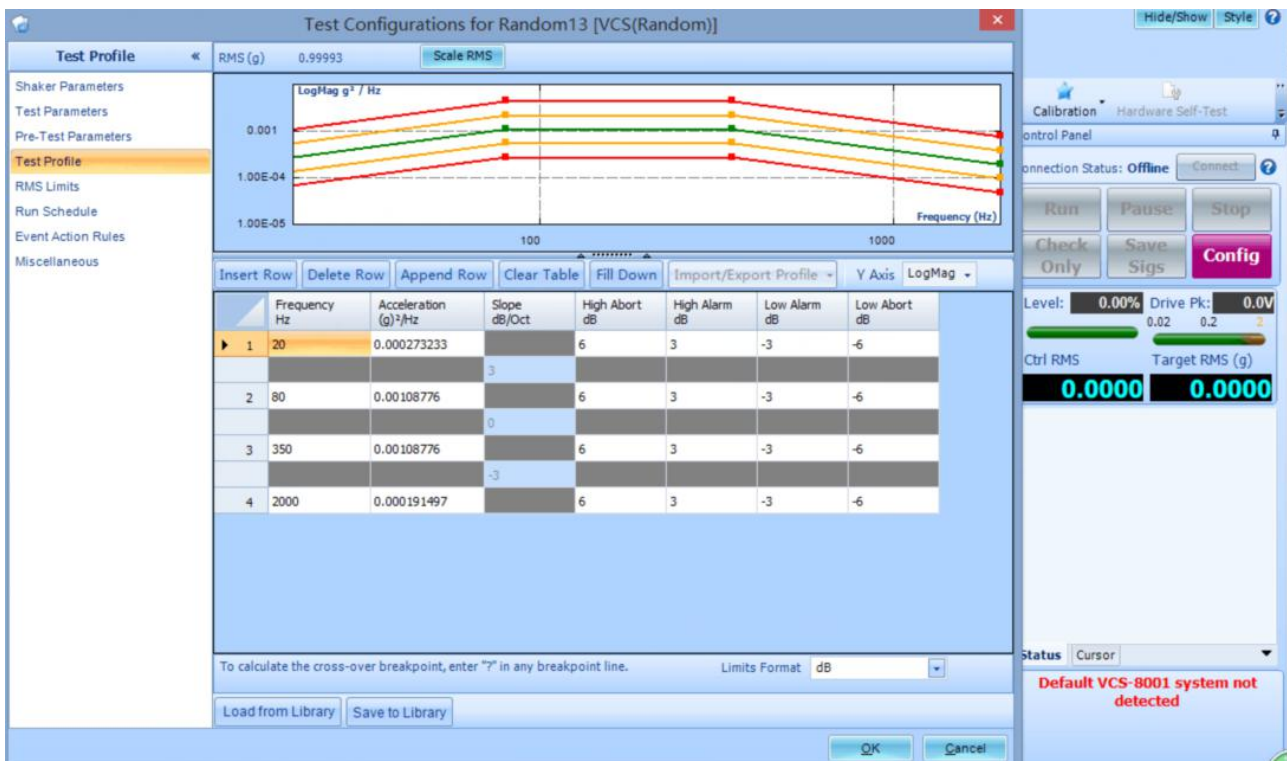

Sine control (Sine)

Sine provides sine frequency sweep signal of simulated mass and controls sine waveform magnitude. It can be used to set dwell magnitude and dwell frequency, and determine dwell duration by setting time or sine signal cycle life.

Frequency range: 1Hz to 5000Hz, extendable to 10000Hz

Closed-loop time: 5 ms

Harmonic distortion: < -100dB

Frequency sweep mode: linear frequency sweep: 0 to 6000 Hz/min

Logarithmic frequency sweep: 0 to 100 Oct/min

Frequency sweep direction: up and down frequency sweep

Frequency sweep duration: frequency and time for frequency sweep can be set.

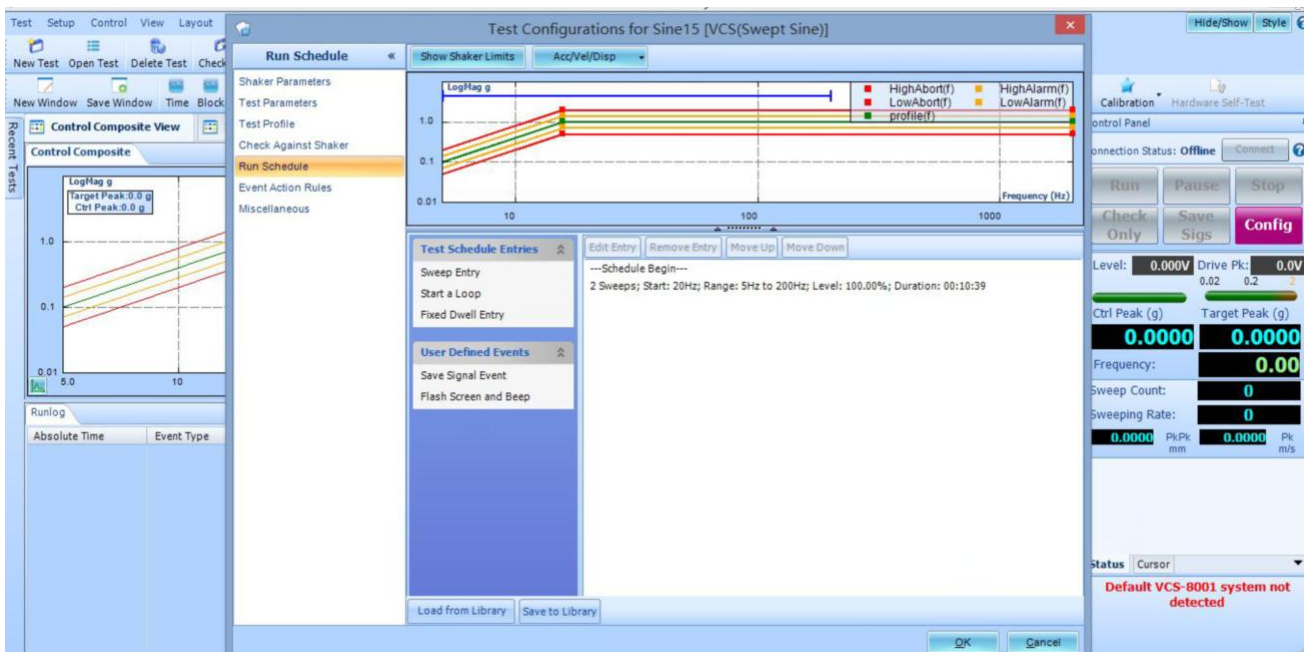

Classical shock

Transfer function equilibrium method is adopted to support semi-sine, bell-shaped wave, square wave, trapezoidal wave, pre-peak saw tooth wave, post-peak saw tooth wave and triangular wave. Users can input pulse peak value as required. The pulse duration is 0.5 to 3000ms.

The max. analysis frequency width is 18750Hz.

Frame size: at most 16384

Applicable standards: MIL-STD-810 (US military standard), ISO standards and interruption control limit value defined by the user

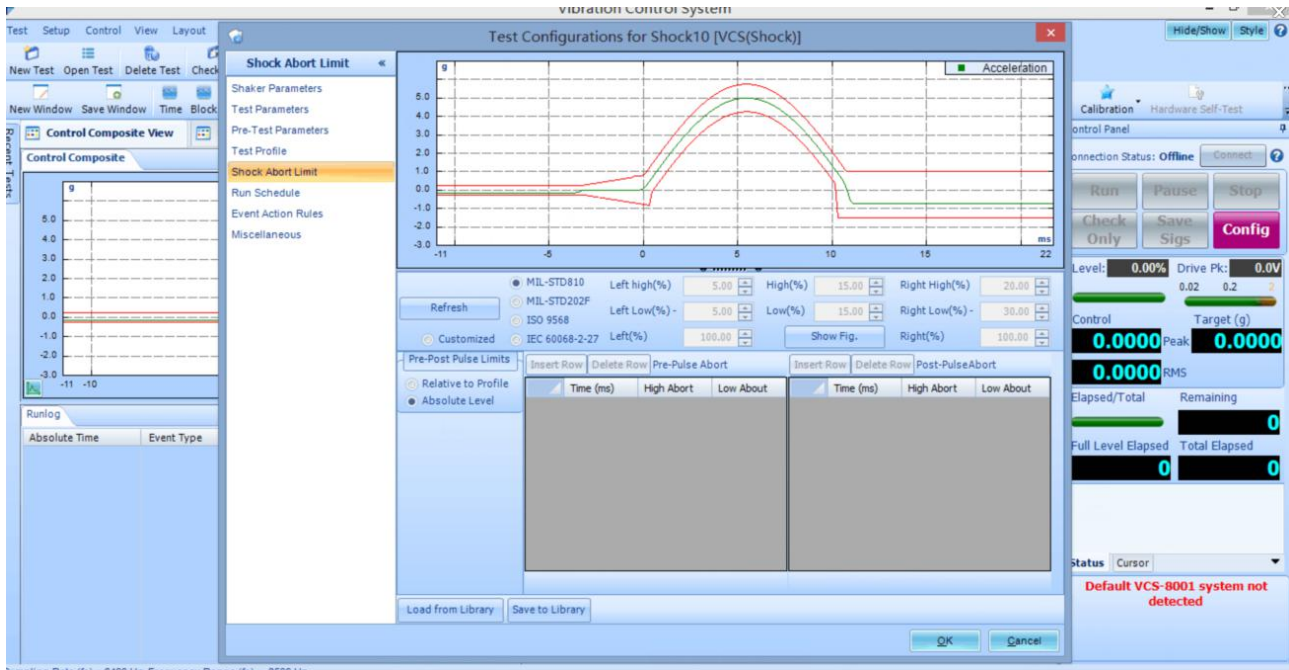

VIII. Equipment Pictures

Control cabinet
(Power
Amplifier, controller, PC)

Cooling Blower

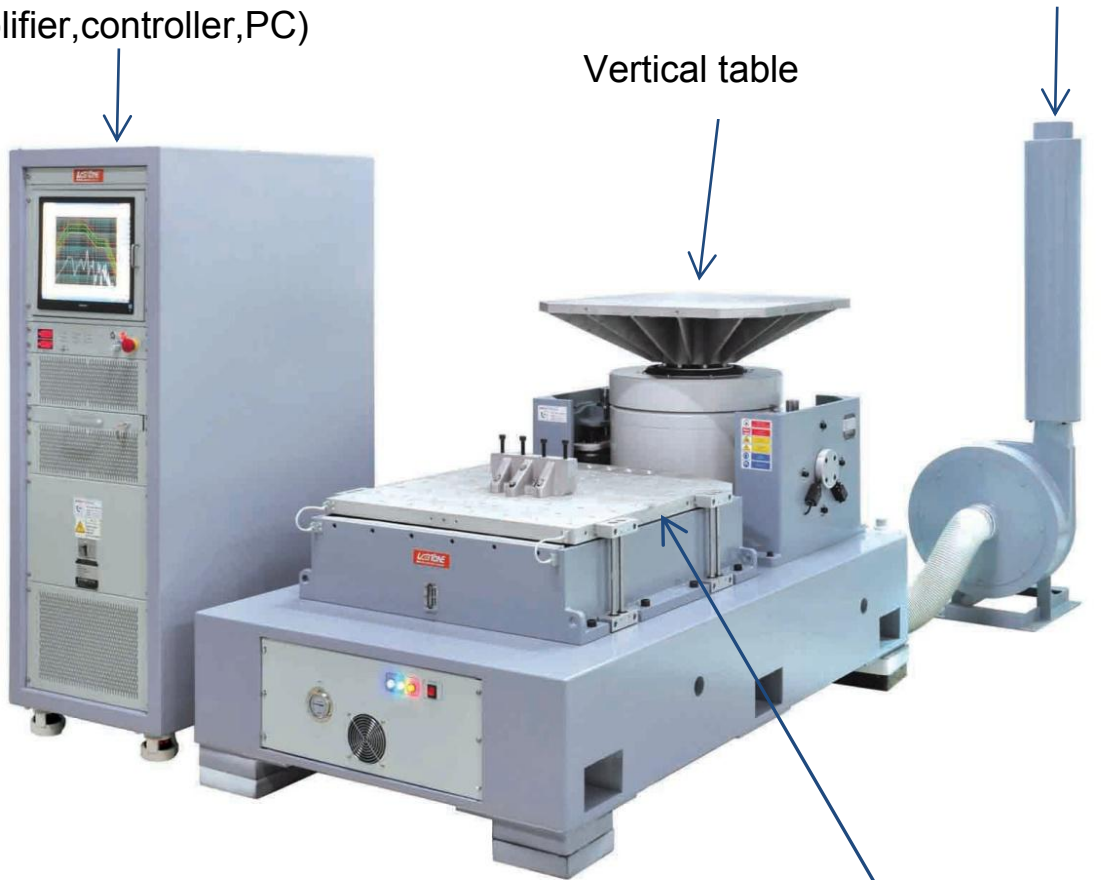

Horizontal slip table

(Product pictures are for reference only)

Equipment handling / loading/unloading requirements

The customer shall prepare corresponding unloading tools.

Note:

The proposal does not represent our final result, and we will provide products and services with high quality / advanced technology / more integrity at fast speed. We appreciate further communication with us, so we can offer you better services.