

English Version

Furniture - Tables - Test methods for the determination of stability, strength and durability

Ameublement - Tables - Méthodes d'essai pour la détermination de la stabilité, de la résistance et de la durabilité

Möbel - Tische - Prüfverfahren zur Bestimmung der Standsicherheit, Festigkeit und Dauerhaltbarkeit

This European Standard was approved by CEN on 18 August 2012.

CEN members are bound to comply with the CEN/CENELEC Internal Regulations which stipulate the conditions for giving this European Standard the status of a national standard without any alteration. Up-to-date lists and bibliographical references concerning such national standards may be obtained on application to the CEN-CENELEC Management Centre or to any CEN member.

This European Standard exists in three official versions (English, French, German). A version in any other language made by translation under the responsibility of a CEN member into its own language and notified to the CEN-CENELEC Management Centre has the same status as the official versions.

CEN members are the national standards bodies of Austria, Belgium, Bulgaria, Croatia, Cyprus, Czech Republic, Denmark, Estonia, Finland, Former Yugoslav Republic of Macedonia, France, Germany, Greece, Hungary, Iceland, Ireland, Italy, Latvia, Lithuania, Luxembourg, Malta, Netherlands, Norway, Poland, Portugal, Romania, Slovakia, Slovenia, Spain, Sweden, Switzerland, Turkey and United Kingdom.



EUROPEAN COMMITTEE FOR STANDARDIZATION
COMITÉ EUROPÉEN DE NORMALISATION
EUROPÄISCHES KOMITEE FÜR NORMUNG

Management Centre: Avenue Marnix 17, B-1000 Brussels

Contents

Page

Foreword.....	3
1 Scope	4
2 Normative references	4
3 Terms and definitions	4
4 General test conditions	5
4.1 Preliminary preparation	5
4.2 Application of forces	5
4.3 Tolerances	5
5 Test Equipment and Apparatus.....	5
6 Test Procedures - Strength and durability	8
6.1 General.....	8
6.2 Horizontal static load test	8
6.3 Vertical static load tests.....	14
6.3.1 Vertical static load on main surface	14
6.3.2 Additional vertical static load test where the main surface has a length > 1 600 mm	15
6.3.3 Vertical static load on ancillary surface	16
6.4 Horizontal durability and stiffness test	17
6.4.1 General.....	17
6.4.2 Horizontal durability test.....	17
6.4.3 Stiffness of the structure	21
6.5 Vertical durability test	23
6.6 Vertical impact test.....	23
6.6.1 General.....	23
6.6.2 Vertical impact test for glass table tops.....	23
6.6.3 Vertical impact test for all other table tops	23
6.7 Deflection of table tops	23
6.8 Durability of tables with castors	24
6.9 Drop test	24
7 Test procedures – Stability	25
7.1 General.....	25
7.2 Stability under vertical load	25
7.2.1 General.....	25
7.2.2 Test for tables that are or can be set to a height of 950 mm or less	25
7.2.3 Test for tables that are or can be set to a height greater than 950 mm	27
7.3 Stability for tables with extension elements.....	27
7.4 Stability of tables designed to support a parasol	27
8 Test procedures - Height adjustment mechanisms	28
8.1 General.....	28
8.2 Durability of Height adjustment mechanisms	28

Foreword

This document (EN 1730:2012) has been prepared by Technical Committee CEN/TC 207 “Furniture”, the secretariat of which is held by UNI.

This European Standard shall be given the status of a national standard, either by publication of an identical text or by endorsement, at the latest by April 2013, and conflicting national standards shall be withdrawn at the latest by April 2013.

Attention is drawn to the possibility that some of the elements of this document may be the subject of patent rights. CEN [and/or CENELEC] shall not be held responsible for identifying any or all such patent rights.

This document supersedes EN 1730:2000.

The main changes with respect to the previous edition are listed below.

- All test methods for seating used in European Standards for furniture have been collated in one document. The document now contains methods that were previously listed in EN 581-3, *Outdoor furniture*, EN 527-3, *Office Work Tables and Desks* and EN 15372, *Non-domestic tables*.
- A durability test for tables with castors has been added.
- A durability test for height adjustment mechanisms has been added.
- Wherever possible test methods have been simplified and clarified for ease of use.

According to the CEN/CENELEC Internal Regulations, the national standards organisations of the following countries are bound to implement this European Standard: Austria, Belgium, Bulgaria, Croatia, Cyprus, Czech Republic, Denmark, Estonia, Finland, Former Yugoslav Republic of Macedonia, France, Germany, Greece, Hungary, Iceland, Ireland, Italy, Latvia, Lithuania, Luxembourg, Malta, Netherlands, Norway, Poland, Portugal, Romania, Slovakia, Slovenia, Spain, Sweden, Switzerland, Turkey and the United Kingdom.

1 Scope

This European Standard specifies test methods for the determination of stability, strength and durability of the structure of all types of tables and desks without regard to use, materials, design/construction or manufacturing process.

This European Standard does not apply to changing units which are covered by other European Standards.

Test methods for the assessment of ageing, degradation, and electrical functions are not included.

This European Standard does not apply to the strength and durability of any storage features that are covered by other European Standards.

This European Standard does not include any requirements. Requirements for different end uses can be found in other Standards.

2 Normative references

The following documents, in whole or in part, are normatively referenced in this document and are indispensable for its application. For dated references, only the edition cited applies. For undated references, the latest edition of the referenced document (including any amendments) applies.

EN 14072:2003, *Glass in furniture — Test methods*

ISO 7619-2, *Rubber, vulcanized or thermoplastic — Determination of indentation hardness — Part 2: IRHD pocket meter method*

3 Terms and definitions

For the purposes of this document, the following terms and definitions apply.

3.1

structure

load bearing parts of furniture such as the frame, top and legs

3.2

ancillary surface

surface additional to the main surface intended for occasional use as part of the table top

3.3

duty cycle

length of time the height adjustable table's drive system may be operated without impairing its useful life

3.4

levelling device

device intended to keep the table top horizontal e.g. adjustable feet or similar

4 General test conditions

4.1 Preliminary preparation

The furniture shall be tested as delivered. Knock-down furniture shall be assembled according to the instructions supplied with it. If the instructions allow the furniture to be assembled or combined in different ways, the most adverse combination shall be used for each test. Knock-down fittings shall be tightened before testing. Further tightening shall not take place unless specifically required by the manufacturer.

Unless otherwise specified by the manufacturer, the sample for test shall be stored in indoor ambient conditions for at least 24 h immediately prior to testing.

The tests shall be carried out at indoor ambient conditions but if during a test the temperature is outside the range 15 °C to 25 °C the maximum and/or minimum temperature shall be recorded in the test report.

The test for deflection of table tops (see 6.7), except those made from metal, glass and stone, shall be carried out at a relative humidity of $(50 \pm 5) \%$ and a temperature of $(23 \pm 2)^\circ \text{C}$.

4.2 Application of forces

The test forces in durability and static load tests shall be applied sufficiently slowly to ensure that negligible dynamic load is applied. The forces in durability tests shall be applied sufficiently slowly to ensure that kinetic heating does not occur.

Unless otherwise stated, static loads shall be maintained for (10 ± 2) s. Unless otherwise stated, durability loads shall be maintained for (2 ± 1) s.

The forces may be replaced by masses. The relationship $10 \text{ N} = 1 \text{ kg}$ shall be used.

4.3 Tolerances

Unless otherwise stated, the following tolerances are applicable to the test equipment:

Forces: $\pm 5 \%$ of the nominal force;

Velocities: $\pm 5 \%$ of the nominal velocity;

Masses: $\pm 1 \%$ of the nominal mass;

Dimensions: $\pm 1 \text{ mm}$ of the nominal dimension;

Angles: $\pm 2^\circ$ of the nominal angle.

The accuracy for the positioning of loading pads and impact plates shall be $\pm 5 \text{ mm}$.

NOTE For the purposes of uncertainty measurement, test results are not considered to be adversely affected when the above tolerances are met.

5 Test Equipment and Apparatus

Unless otherwise stated, the tests may be applied by any suitable device because the results are not dependent upon the apparatus, except in the case of impact tests where the apparatus described in 5.2 shall be used.

The equipment shall not inhibit deformation nor cause unnatural deformation of the unit/component, i.e. it shall be able to move so that it can follow the deformation of the unit/component during testing.

With the exception of the horizontal static, durability and stiffness tests, described in 6.2 and 6.4, all loading pads shall be capable of pivoting in relation to the direction of the applied force and the pivot point shall be as close as practically possible to the load surface.

Loading pads for the horizontal static, durability and stiffness tests, described in 6.2 and 6.4, shall not pivot.

With the exception of the horizontal static, durability and stiffness tests described in 6.2 and 6.4, if a loading pad tends to slide, use a slip resistant material between the loading pad and the surface being tested.

5.1 Vertical impactor, as shown in Figure 1 and comprised of the following:

5.1.1 Circular body, 200 mm in diameter separated from the striking surface by helical compression springs and free to move relative to it on a line perpendicular to the plane of the central area of the striking surface.

The body and associated parts minus the springs shall have a mass of $(17 \pm 0,1)$ kg and the whole apparatus, including mass, springs and striking surface, shall have a mass of $(25 \pm 0,1)$ kg.

5.1.2 Springs, which shall be such that the nominal spring rate of the combined spring system is (7 ± 2) N/mm and the total friction resistance of the moving parts is less than 1 N.

The spring system shall be compressed to an initial load of $(1\ 040 \pm 5)$ N (measured statically) and the amount of spring compression movement available from the initial compression point to the point where the springs become fully closed shall be not less than 60 mm.

5.1.3 Striking surface, which shall be a rigid circular object, 200 mm in diameter, the face of which has a convex spherical curvature of 300 mm radius with a 12 mm front edge radius.

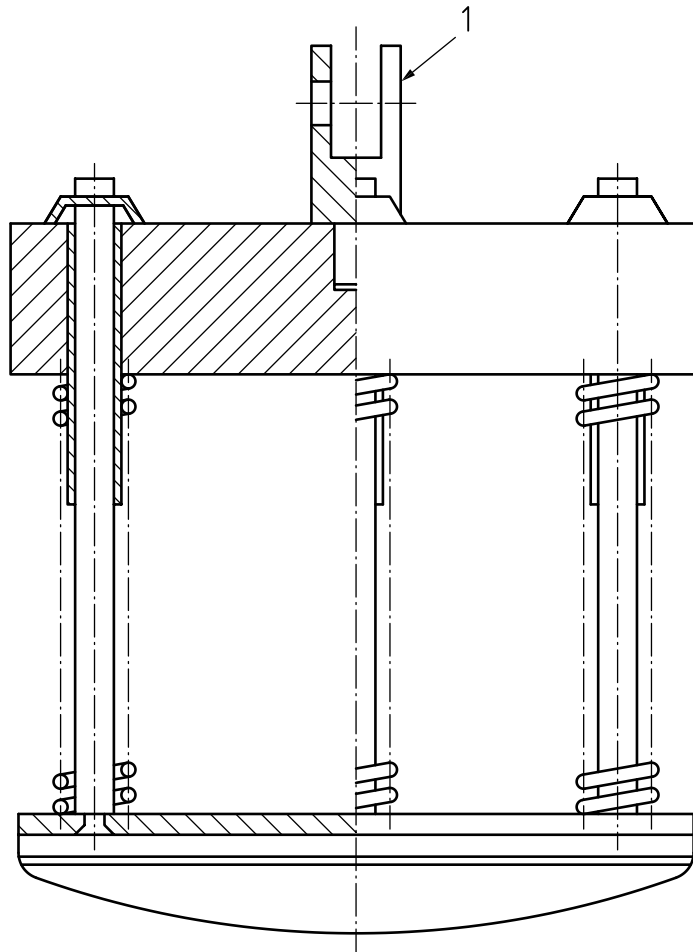
**Key**

- 1 joint of lifting device not inhibiting free fall

Figure 1 — Vertical Impactor

5.2 Floor, horizontal, flat and rigid with a smooth surface.

For the drop test (6.9) the floor shall be faced with a 2 mm thick layer of rubber with a hardness of 85 ± 10 IRHD according to ISO 7619-2.

5.3 Stops, to prevent the article from sliding but not tilting, no higher than 12 mm except in cases where the design of the item necessitates the use of higher stops, in which case the lowest that will prevent the item from moving shall be used.

5.4 Loading pad, a rigid cylindrical object, 100 mm in diameter, with a flat, smooth face and a 12 mm edge radius.

5.5 Foam, 25 mm thick layer of flexible foam with a bulk density of $(120 \pm 25) \text{ kg/m}^3$.

5.6 Steel test tube, $(18 \pm 1,5)$ mm in diameter and $(1,5 \pm 0,5)$ mm in wall thickness with a length such that a force can be applied at a distance of 2 200 mm above the floor.

5.7 Test surface for castor durability tests, horizontal, flat smooth and rigid steel surface.

5.8 Obstacles for castor durability tests, steel strips 50 mm wide and 2 mm high with the top edges having a radius of 2 mm, 500 mm apart and parallel on the floor surface and perpendicular to the test direction.

6 Test Procedures - Strength and durability

6.1 General

Unless otherwise specified, the tests shall be carried out in the configuration most likely to cause failure.

Where the table top can be extended, and the smallest dimension of the unextended table top is less than 300 mm, then the extended configuration shall be considered most likely to cause failure. In this case, the extended configuration is considered to be the main surface.

Levelling devices shall be set as near as possible to 5 mm from the fully open position whilst ensuring the table top is parallel to the floor.

If a test cannot be carried out as specified in this standard, e.g. because a loading pad cannot be used for the application of a force due to the design of a product, the test shall be carried out as far as possible as specified.

Tables supplied with storage features shall be tested with the specified load in the storage item.

6.2 Horizontal static load test

Position the table on the test surface, in its normal position of use without extending, or inserting, ancillary surfaces.

Unless otherwise specified, height adjustable tables shall be set to their highest position. Restrain the base of the table by stops placed in all directions at the opposite end to that at which the horizontal test force is first to be applied.

Apply the specified mass to an area of (300 ± 50) mm x (300 ± 50) mm, or a diameter of (300 ± 50) mm, to the approximate centre of the table top.

Apply the specified horizontal force by means of the loading pad (5.4) at the table top level in a direction perpendicular to a line joining the two legs/supports, midway between the legs/supports. See Figures 2a, 2c, 2e, 2g and 2i.

If the table top is not secured to the understructure and the top moves when the specified force is applied, reduce the force sufficiently to just prevent movement. Record the force applied. The applied force shall not be reduced below the minimum specified force.

If the unrestrained base lifts when the specified force is applied, reduce the force sufficiently to just prevent lifting. Record the force applied. The applied force shall not be reduced below the minimum specified force. If unrestrained base lifts at this force, the specified mass applied to the table top shall be increased gradually until this tendency ceases.

Leaving the stops in position, use the same procedure to determine the force to be applied in the opposite direction.

One application of the force in each direction represents one cycle.

Repeat the test method applying the specified horizontal force at the work top level along the line joining the two legs/supports. See Figures 2b, 2d, 2f, 2h and 2j.

Apply the same force in the opposite direction.

One application of the force in each direction represents one cycle.

Repeat this procedure until each unique leg design/construction has been tested.

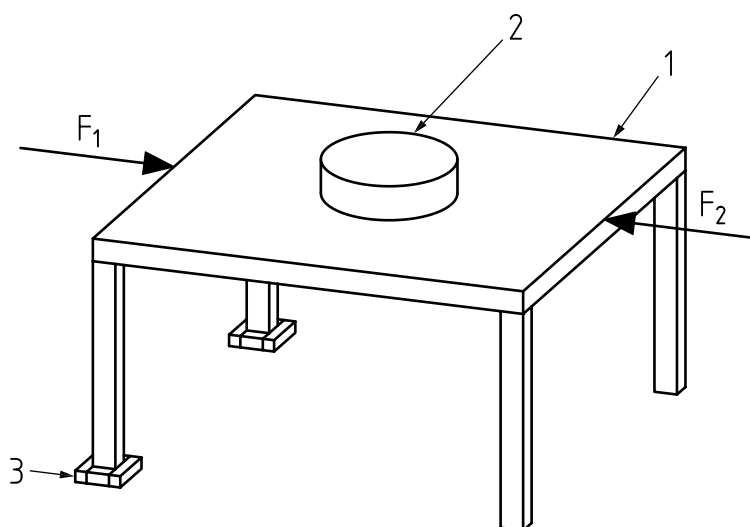

a) Rectangular table – first and second directions

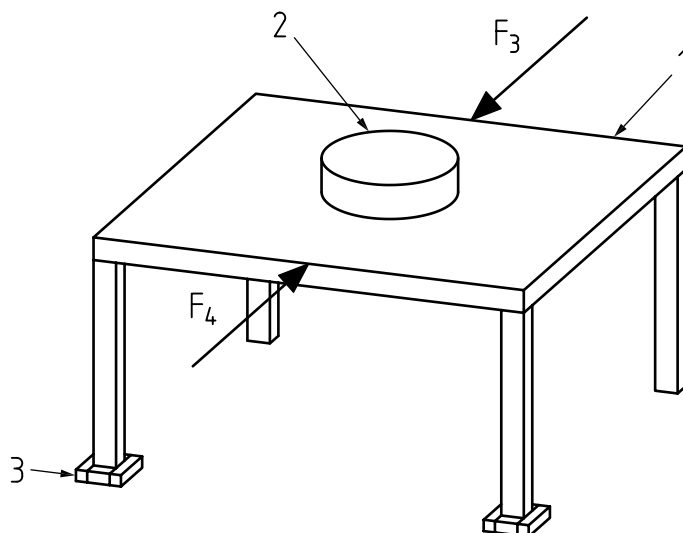

b) Rectangular table – third and fourth directions

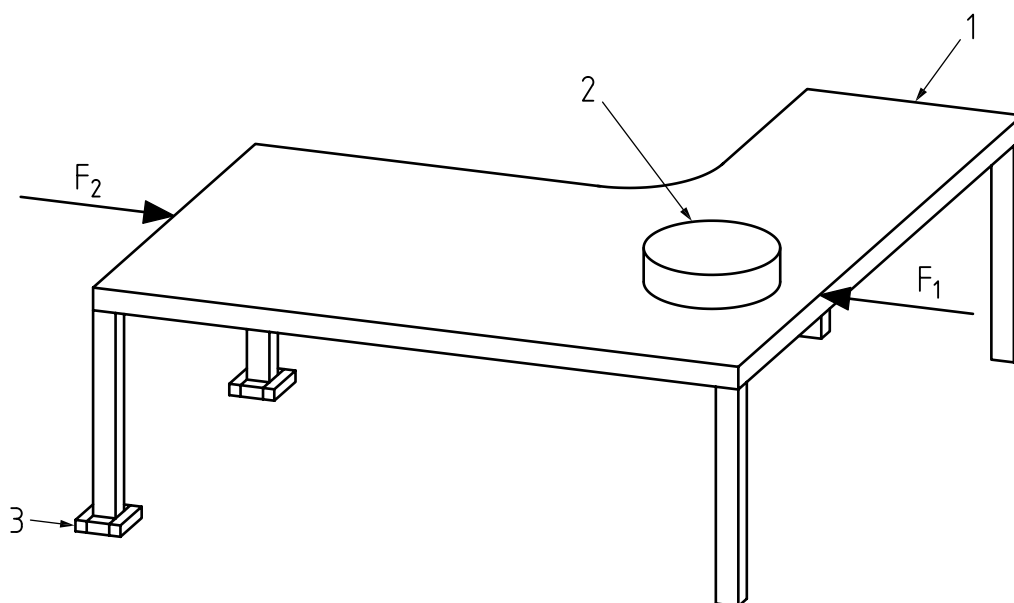

c) Irregular shape table - first and second directions

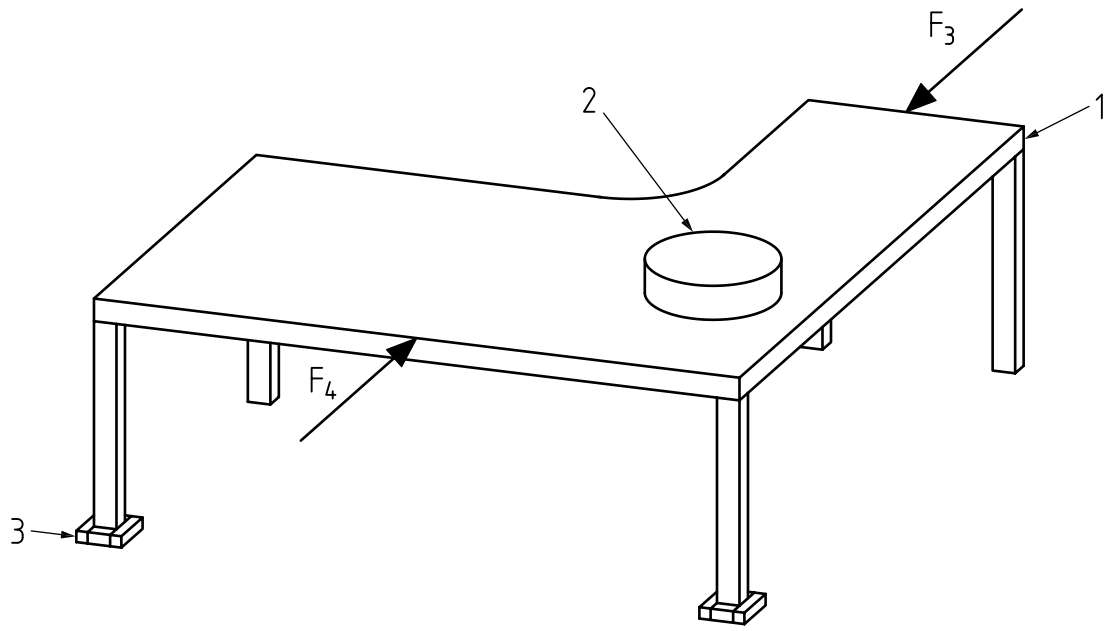

d) Irregular shape table - third and fourth directions

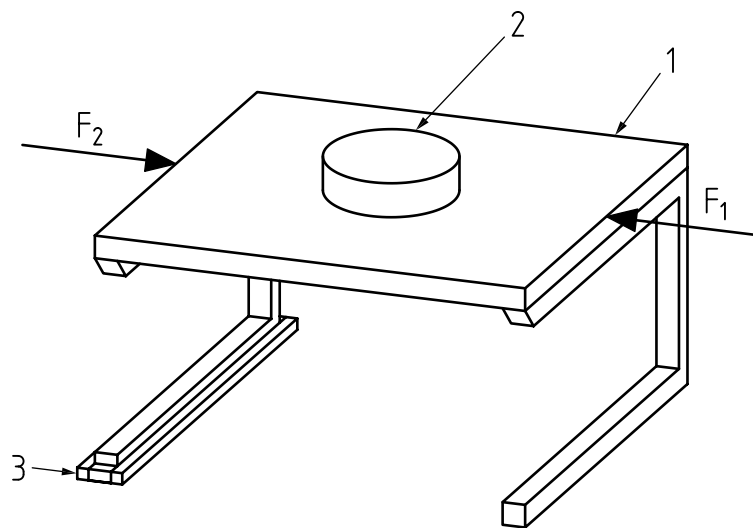

e) Cantilever table – first and second directions

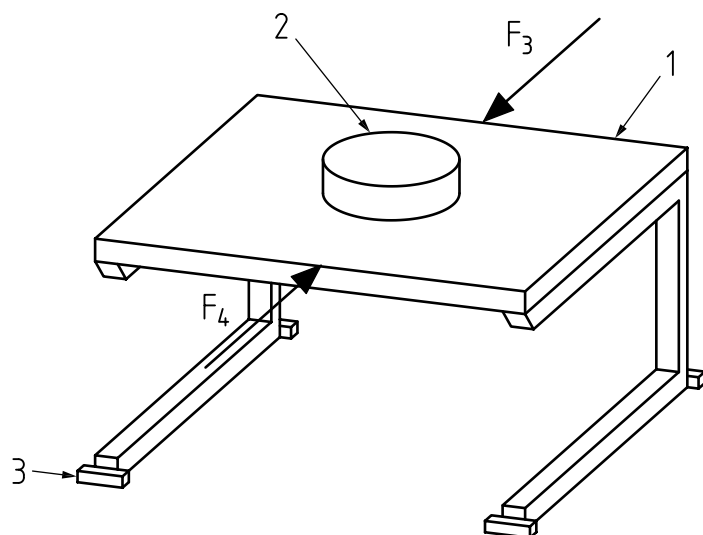

f) Cantilever table – third and fourth directions

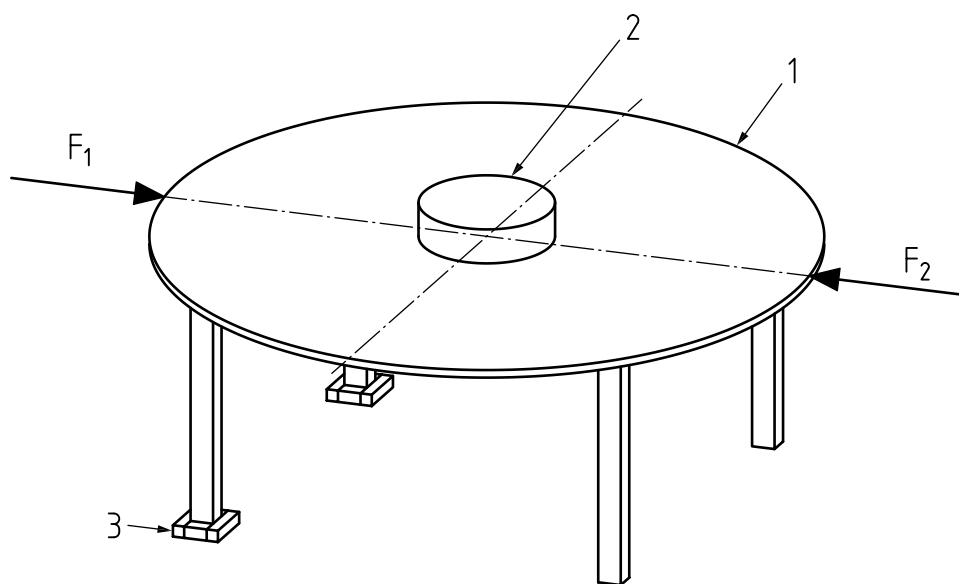

g) Oval/round table – first and second directions

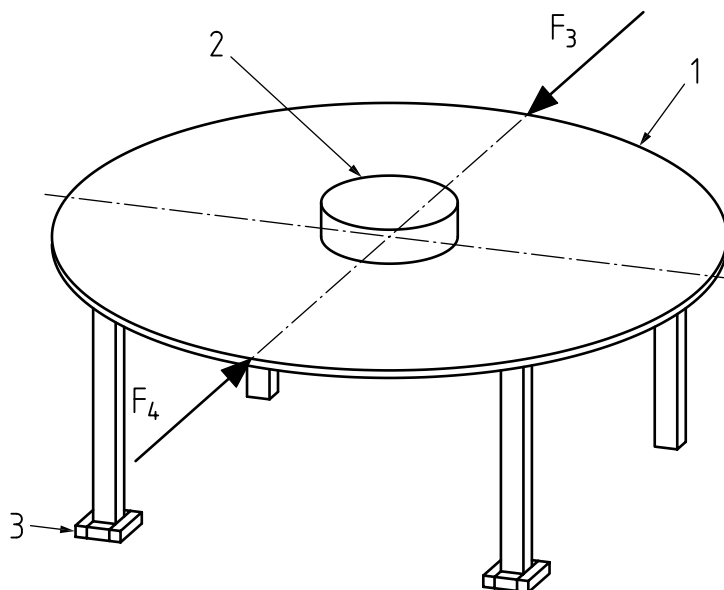

h) Oval/round table – third and fourth directions

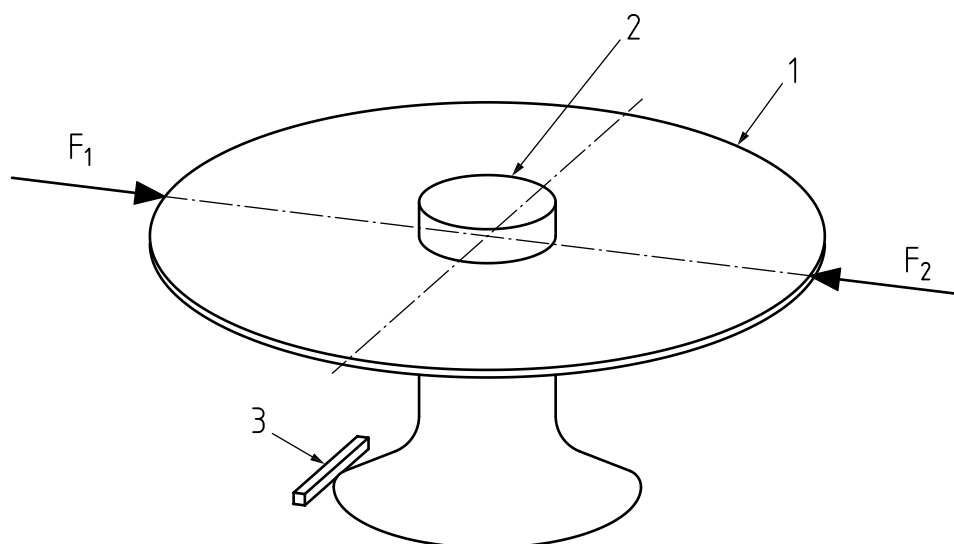

i) Oval/round table with central column – first and second directions

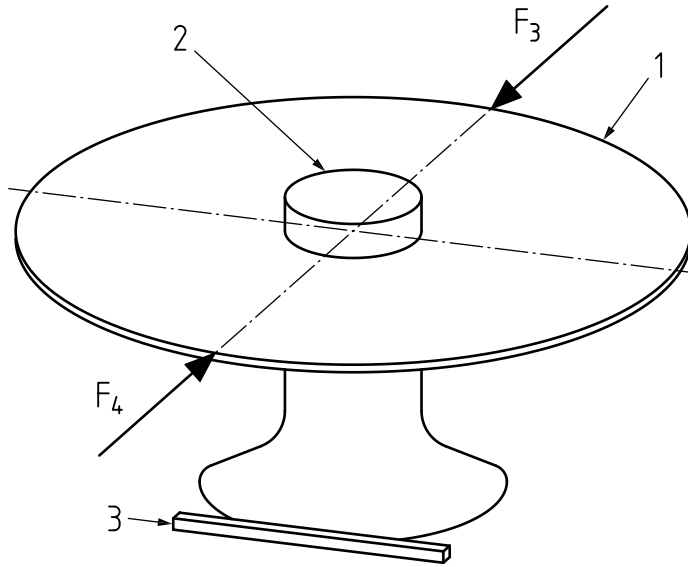

j) Oval/round table with central column – third and fourth directions

Key

- | | |
|---------------------------------|------------------|
| F_1 force in first direction | 1 table |
| F_2 force in second direction | 2 specified mass |
| F_3 force in third direction | 3 stop |
| F_4 force in fourth direction | |

Figure 2 — Examples of positions of forces and stops in horizontal static load tests

6.3 Vertical static load tests

6.3.1 Vertical static load on main surface

A table extension added in the centre of the table shall be considered as the main surface.

Apply a vertical downward force using the loading pad (5.4) anywhere on the top that is likely to cause a failure, but not less than 100 mm from any edge (see Figure 3).

If the table tends to overturn gradually, move the loading point towards the centre of the table until this tendency ceases.

If there are several such positions, carry out the test at a maximum of four different positions. If deflection measurements are required, maintain the last load for up to 30 min in order to measure the maximum deflection, d . The deflection, d , is the difference in height at the point of loading, between the initial unloaded state and the final state under load.

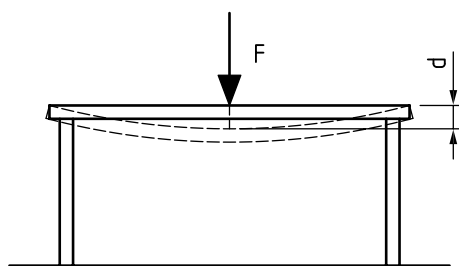

a) Main surface

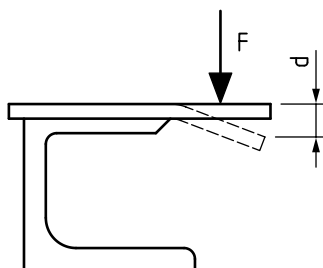

b) Cantilever support

Key

- d deflection
- F vertical static load

Figure 3 — Vertical static load test – main surface**6.3.2 Additional vertical static load test where the main surface has a length > 1 600 mm**

A table extension added in the centre of the table shall be considered as the main surface.

Apply two vertical downward forces simultaneously using the loading pad (5.4) at points positioned on the longitudinal axis of the table top, 400 mm on either side of the transversal axis. See Figure 4.

All dimensions in millimetres

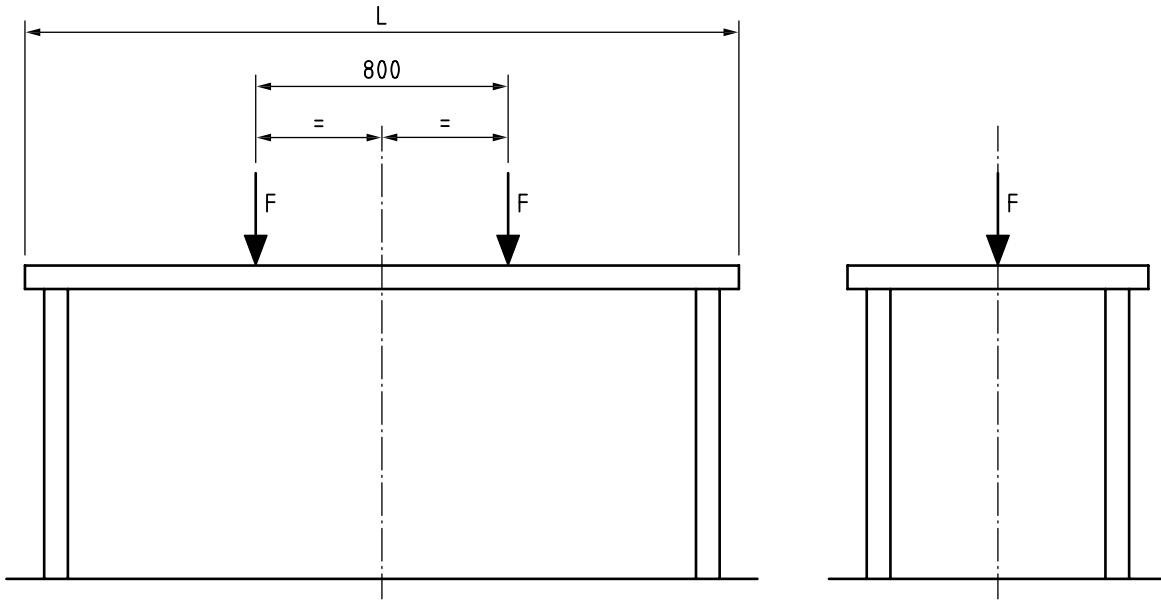

Key

- L length of top
- F vertical static load

Figure 4 — Additional vertical static load test

6.3.3 Vertical static load on ancillary surface

A table extension added in the centre of the table shall be considered as the main surface. A part of the main surface in the unextended configuration may become an ancillary surface in the extended configuration.

Apply a vertical downward force using the loading pad (5.4) anywhere on the ancillary surface that is likely to cause a failure, but not less than 100 mm from any edge (see Figure 5).

If the article tends to overturn, load the main table top gradually to prevent overturning.

If there are several such positions repeat the test at a maximum of two different positions.

If deflection measurements are required, maintain the last load for up to 30 min in order to measure the maximum deflection, *d*. The deflection, *d*, is the difference in height at the point of loading, between the initial unloaded state and the final state under load.

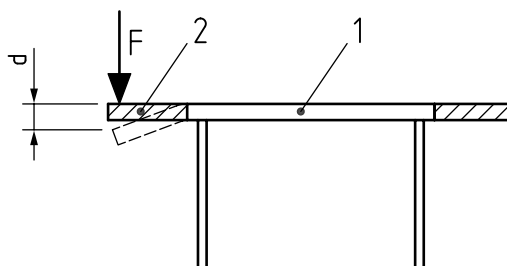

Key

d	deflection	1	main surface
F	vertical static load	2	ancillary surface

Figure 5 — Vertical static load test – ancillary surface

6.4 Horizontal durability and stiffness test

6.4.1 General

Position the table on the test surface, in its normal position of use. Tables with extensions inserted in the centre shall be tested in the extended configuration. All other tables shall be tested without extending ancillary surfaces.

Restrain the base of the table by placing stops around each leg/base (in all directions) (see Figure 6).

Place the specified mass on the table top on an area of (300 ± 50) mm x (300 ± 50) mm, or a diameter of (300 ± 50) mm, at the point most likely to prevent the table lifting off the floor.

6.4.2 Horizontal durability test

Apply two alternating horizontal forces at the table top level by means of two loading pads (5.4), one at one end of the table 50 mm from one corner/edge, a, (and one at the opposite end/edge, b, (see Figure 6 a)).

If the table top is not secured to the understructure and the top moves when the specified force is applied, reduce the force sufficiently to prevent movement. Perform the test using this reduced force in that direction only. Record the value of any reduced force used.

If the table tends to lift in one direction of loading at a load less than that specified, reduce the horizontal force to the value determined at the beginning of the test process. Perform the test using this reduced force in that direction only. Record the value of any reduced force used.

Repeat the procedure at the other corner positions, c and d, (see Figure 6 a)).

Carry out the test for the number of cycles specified.

The test may be carried out in a one stage cycle a, c, b, d or in a two stage cycle a, b followed by c, d.

For table tops with a cantilever support at one end, carry out the test as shown in Figure 6 b).

For table tops attached to another table top at one end, carry out an additional test as shown in Figure 6 c).

If measurements of the horizontal movement are required, this shall be measured at the beginning and end of the test, when the load is changed from one end to the opposite end.

For tables with circular or oval tops, direction a, b shall be through the longitudinal axis. Direction c, d shall be on a line perpendicular to the direction a, b and 50 mm from outermost edge of the table (see Figure 6 d)).

For tables with curved table tops special loading pads may be used.

For tables with a triangular base or three legs, direction a, b shall be perpendicular to one side of the base or to the line joining two legs and passing throughout the third corner of the base or the third leg. Direction c, d shall be parallel to one side of the base or the line joining two legs. For tables with circular or oval tops, and featuring a triangular base or three legs, a, b shall be through the longitudinal axis. Direction c, d shall be on a line perpendicular to the direction a, b and 50 mm from outermost edge of the table (see Figure 6 e)).

For tables with circular or oval tops, and featuring a cross leg support, direction a, b shall be through the longitudinal axis. Direction c, d shall be on a line perpendicular to the direction a, b and 50 mm from outermost edge of the table (see Figure 6 f)).

All dimensions in millimetres

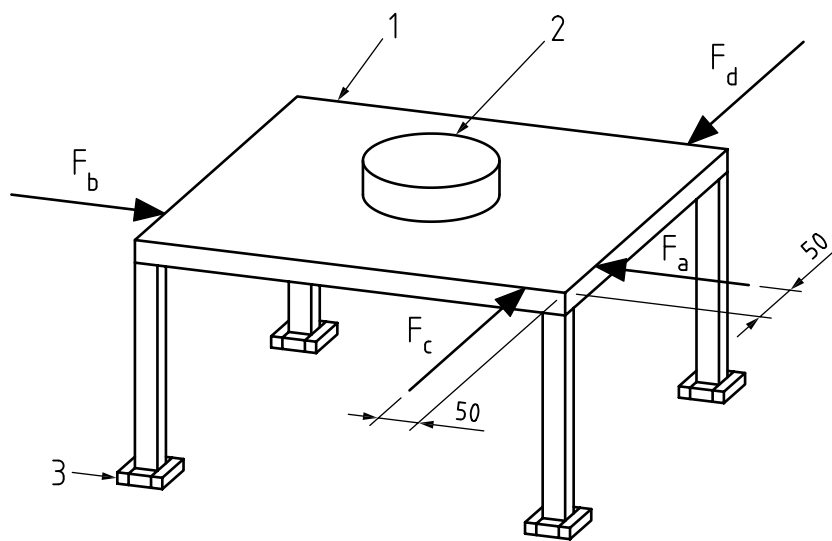

a) Main surface

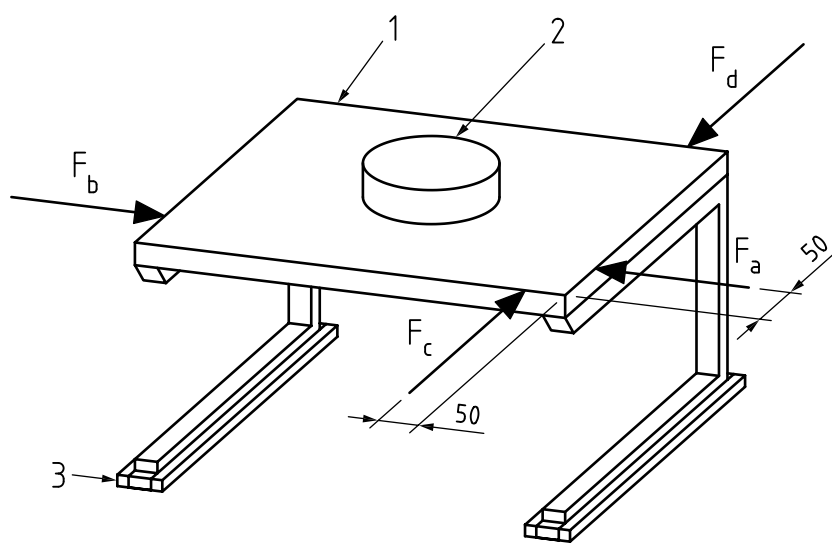

b) Cantilevered tables

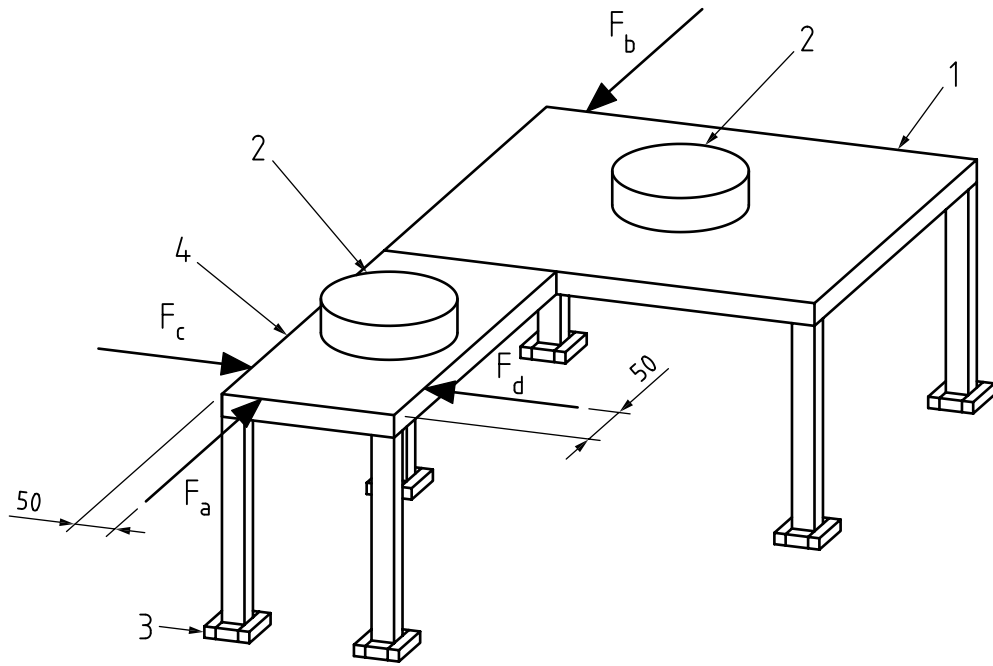

c) Additional tops

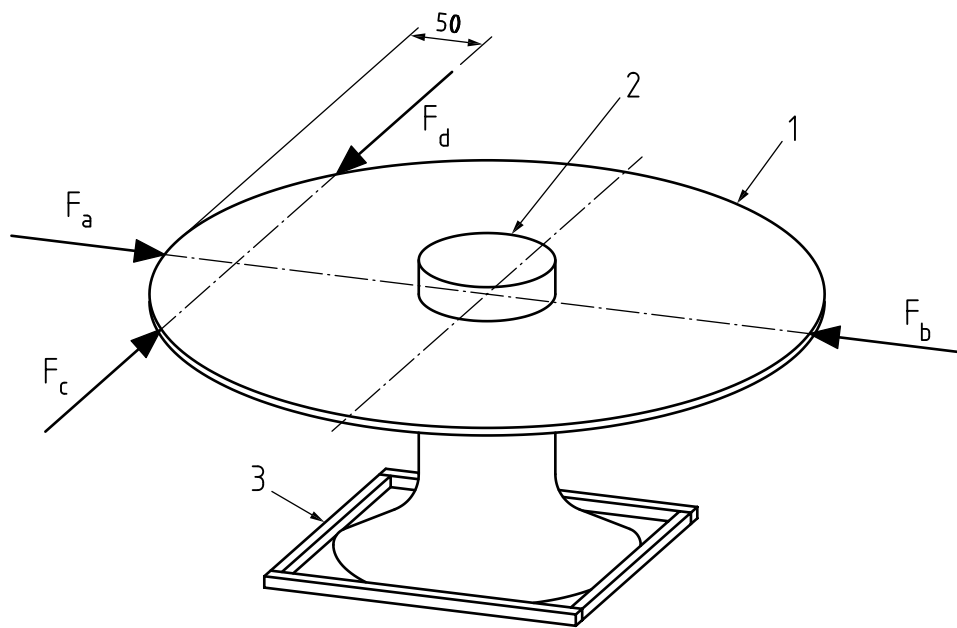

d) Round and elliptical tops

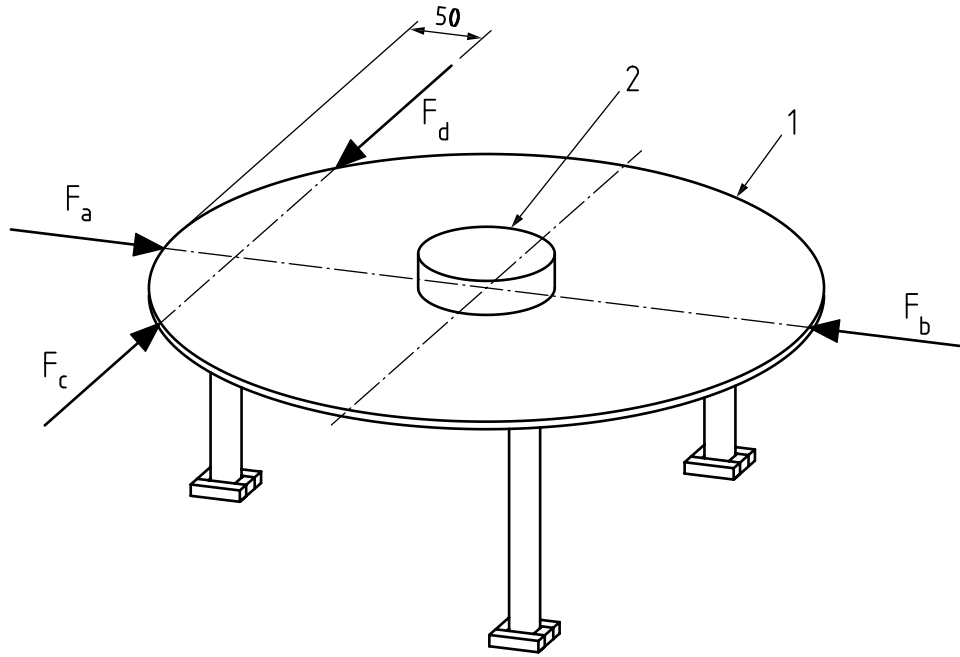

e) Round and elliptical tops with three legs

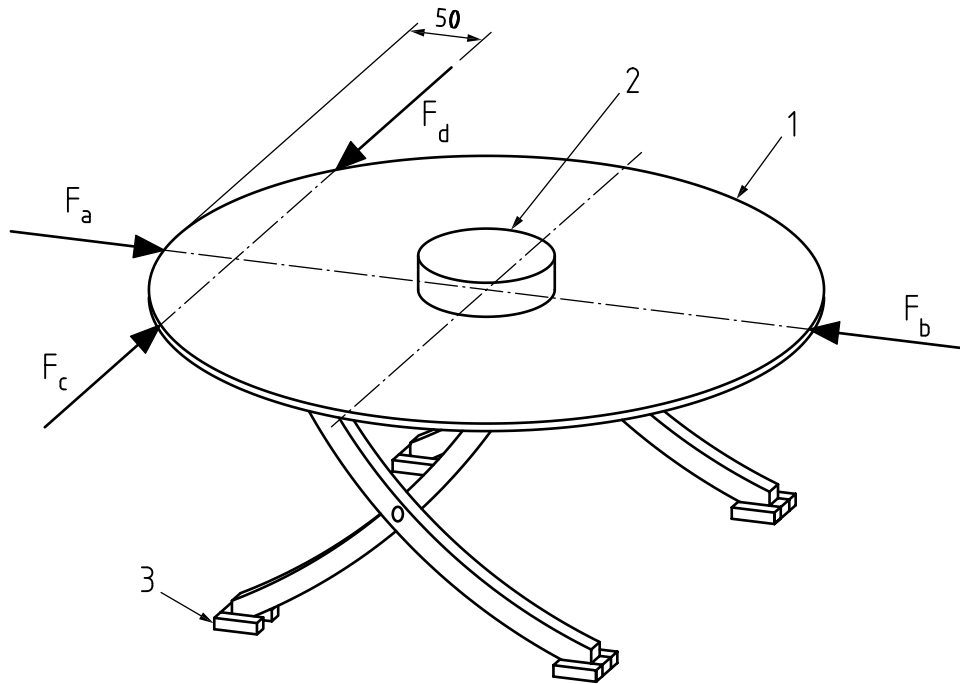

f) Round and elliptical tops with crossing legs

Key

- | | |
|--------------------------------|------------------|
| F_a force applied at point a | 1 main table top |
| F_b force applied at point b | 2 specified mass |
| F_c force applied at point c | 3 stops |
| F_d force applied at point d | 4 additional top |

Figure 6 — Horizontal durability test

6.4.3 Stiffness of the structure

Apply the test force by means of the loading pad (5.4), at the table top level in a direction perpendicular to a line joining two legs/supports and midway between the legs/supports, or midway between the outermost legs for a table with more than two legs in a straight line.

Maintain the force for (10 ± 1) s and record the position of a point D on the length of the table. Remove the force and repeat it in the opposite direction and record the distance of the horizontal travel of the point. The total distance point D moves, from its location when the force in one direction is applied to its location when the force is applied in the other direction, is D_1 . (See Figure 7 a)) Calculate and record D_1 .

Repeat the procedure using horizontal forces along the transverse centreline. The total distance point D moves, from its location when the force in one direction is applied to its location when the force is applied in the other direction, is D_2 . (See Figure 7 b)) Calculate and record D_2 .

If the table top is not secured to the understructure and the top moves when the specified force is applied, reduce the force sufficiently to prevent movement. Perform the test using this reduced force in that direction only. Record the value of any reduced force used.

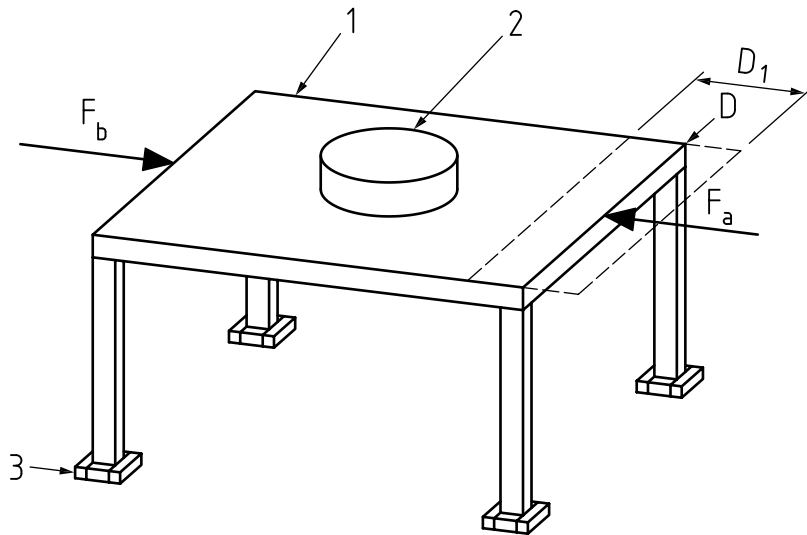

a) Longitudinal direction

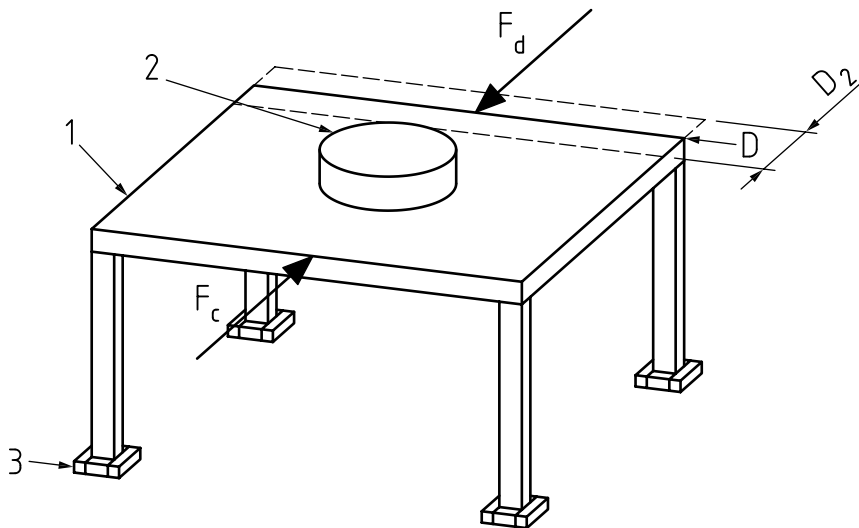

b) Transverse direction

Key

- | | |
|-------------------------------------|------------------|
| F_a force applied at point a | 1 main table top |
| F_b force applied at point b | 2 specified mass |
| F_c force applied at point c | 3 stops |
| F_d force applied at point d | |
| D measurement point | |
| D_1 distance travelled by point D | |
| D_2 distance travelled by point D | |

Figure 7 — Stiffness of the structure

6.5 Vertical durability test

Position the table on the test surface in its normal position of use. Tables with extensions inserted in the centre shall be tested in the extended configuration. All other tables shall be tested without extending ancillary surfaces.

Apply the vertical force specified in the requirement document by means of the loading pad (5.4), on the table top at the most adverse position, 100 mm from the table top edge.

If the article tends to lift, load the centre of the main table top with a mass sufficient to prevent overturning.

Carry out the test for the number of cycles specified.

6.6 Vertical impact test

6.6.1 General

Position the table on the test surface, in its normal position of use. Tables with extensions inserted in the centre shall be tested in the extended configuration. All other tables shall be tested without extending ancillary surfaces.

6.6.2 Vertical impact test for glass table tops

For the vertical impact testing of tables, incorporating glass tops shall be tested in accordance with EN 14072:2003, Clause 6.

6.6.3 Vertical impact test for all other table tops

Place one layer of foam (5.5) on the table top.

The height of drop shall be measured from the position where the impactor is resting on the surface of that layer of foam. Place a second layer of foam (5.5) between the striking surface and the table top.

Allow the vertical impactor (5.1) to fall freely from the height specified in the requirement document onto the foam surface at the following positions:

- as close as possible to one point of support of the top but not less than 100 mm from any edge;
- 100 mm from the edge of the top as far away from the supports as possible;
- 100 mm from the edges at one corner.

6.7 Deflection of table tops

Position the table on the test surface, in its normal position of use. Tables with extensions inserted in the centre shall be tested in the extended configuration. All other tables shall be tested without extending ancillary surfaces.

Testing of the deflection of table tops that are not made of metal, glass or stone, shall be carried out in a relative humidity as specified in 4.1.

The greatest deflection shall be measured and recorded with reference to a straight line to an accuracy of $\pm 0,1$ mm.

Place the table being tested on the floor surface (5.2). Load the table top with a uniformly distributed load as specified and apply for:

- one hour for table tops made of metal, glass and stone;
- one week for all other table tops.

With the load remaining on the top, measure and record the deflection at a point 50 mm from an edge where the deflection is greatest, with reference to a straight edge placed along and extending the entire length or diameter of the table top. The deflection is the difference in height between the initial unloaded state and the final state under load.

6.8 Durability of tables with castors

This test is only applicable to tables that have castors fitted to all legs/supports.

Tables shall be tested without extending or inserting ancillary surfaces.

Place the table on the floor surface (5.2).

Apply the specified load, centred on the table.

The castors shall be free to rotate and swivel.

The operating force shall be applied no lower than 50 mm from the top surface of the table.

At least one castor shall be run over obstacles (5.8) at a mean speed of 0,2 m/s for a distance of one metre. At the end of one metre the direction of travel shall be reversed and the castor shall return to the starting point. This cycle shall be repeated until the castors have been running for 2 min.

There shall be a cooling period of 2 min before the next 2 min test run is started.

The procedure shall be repeated until the specified number of cycles has been completed. One cycle consists of one movement forwards and backwards.

Inspect the castors and the structure for damage affecting the function.

6.9 Drop test

Place the table unloaded on the floor surface (5.2), in its normal position of use, without ancillary surfaces inserted or extended, but with ancillary surfaces in their normal stored position. Height adjustable tables shall be set to their lowest position.

Determine the drop height as a percentage of the specified nominal drop height in accordance with Table 1.

The vertical force is determined as the lowest upwards vertical force to lift at least one leg/support off the floor (10 ± 5) mm off the floor.

For tables that have a single leg/support the vertical force is determined as the lowest upwards vertical force to lift the edge of the support (10 ± 5) mm off the floor.

Table 1 — Determination of drop height

Vertical force	% of specified nominal drop height
0 N - < 200 N	100
200 N – 400 N	$100 - \left[70 \times \frac{[force\ to\ lift\ one\ end\ of\ unit - 200]}{200} \right]$
> 400 N	30

Determine and record the most likely lifting point(s).

Lift the table at the point used to determine the vertical force to the drop height and let it drop freely onto the floor surface (5.2).

Carry out the test six times. Height adjustable tables shall be tested three times at the lowest position and three times at the highest position.

7 Test procedures – Stability

7.1 General

Unless otherwise specified, the tests shall be carried out in the configuration most likely to cause overturning.

Where the table top can be extended, and the smallest dimension of the unextended table top is less than 300 mm, then the extended configuration shall be considered most likely to cause failure. In this case, the extended configuration is considered as the main surface.

Levelling devices shall be set as near as possible to 5 mm from the fully open position whilst ensuring the table top is parallel to the floor.

If a test cannot be carried out as specified in this standard, e.g. because a loading pad cannot be used for the application of a force due to the design of a product, the test shall be carried out as far as possible as specified.

With the exception of 7.3, tables supplied with storage features shall be tested with no load in the storage item.

7.2 Stability under vertical load

7.2.1 General

Tables that can be set to heights both above and below 950 mm shall be tested to both 7.2.2 and 7.2.3.

7.2.2 Test for tables that are or can be set to a height of 950 mm or less

The table shall be set to the height most likely to overturn the table, but not more than 950 mm.

Measure the longest dimension of the table top (L). Apply the specified vertical load (V), determined from Table 2.

NOTE A graphical representation of Table 2 is shown in Figure 8.

The vertical load shall be applied 50 mm from the outer edge of the table top (see Figure 9) on that side where the load is most likely to cause overturning as far away from the supports as possible.

Where there are multiple positions that may cause overturning the test should be repeated at each position.

Table 2 — Determination of vertical load

Longest dimension, L, of the table top in the overturning direction	Vertical load V
0 mm - < 800 mm	V_1
800 mm – 1 600 mm	$V_2 - (V_2 - V_1) \times \frac{(1\,600 - L)}{800}$
> 1 600 mm	V_2

All dimensions in millimetres

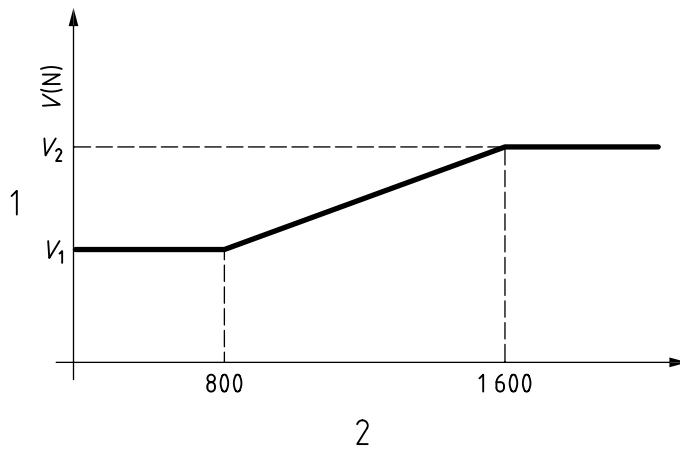

Key

- 1 vertical force (V) in N
- 2 longest dimension of the table top in mm
- V₁ minimum vertical force
- V₂ maximum vertical force

Figure 8 — Determination of vertical stability load

All dimensions in millimetres

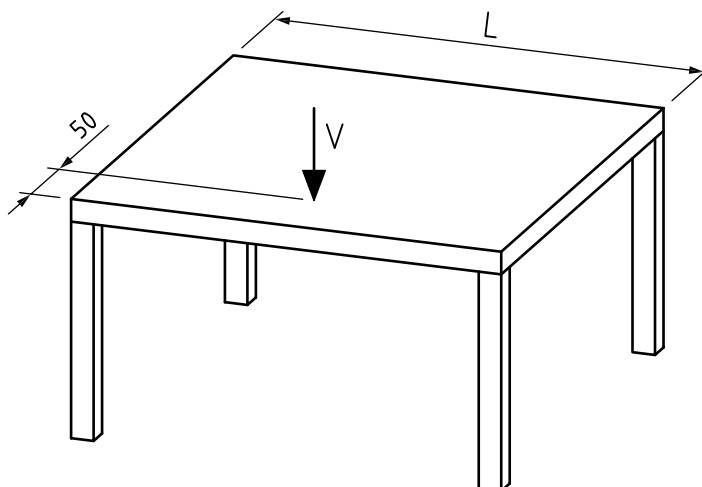
**Key**

- L longest dimension of table top
- V vertical load

Figure 9 — Vertical stability test**7.2.3 Test for tables that are or can be set to a height greater than 950 mm**

The table shall be set to the height most likely to cause overturning, but not less than 950 mm.

The table shall not overturn when tested according to 7.2.2 using 50 % of the specified vertical load (V) determined from Table 2.

Where there are multiple positions that may cause overturning the test should be repeated at each position.

7.3 Stability for tables with extension elements

Load each extension element with the load specified.

For tables with extension elements not fitted with interlocks, open all extension elements in the least favourable combination. For tables with extension elements fitted with interlocks, open the two extension elements with the largest loads without overriding the interlock. If an interlock device prevents any two of the extension elements from being opened simultaneously, open the extension element with the largest load.

The table shall not overturn when the specified vertical force is applied at the centre of the front of the table, through a loading pad (5.4), 50 mm from the edge.

7.4 Stability of tables designed to support a parasol

This test does not apply if the table shall be used with parasols that are fitted with their own bases.

Secure the test tube (5.6) in the table's fixture for holding parasols.

Apply the specified horizontal force F at a height h of 2 200 mm. Figure 10 shows an example of a table where the structure is intended to support a parasol.

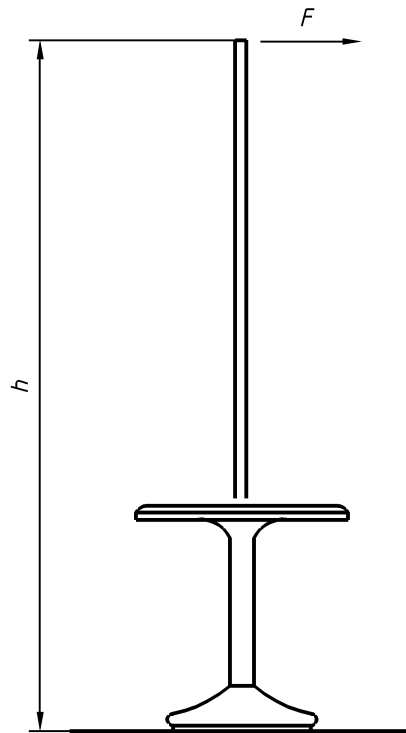

Key

F horizontal force

h height

Figure 10 — Stability of tables where the structure is intended to support a parasol

8 Test procedures - Height adjustment mechanisms

8.1 General

This test is only applicable to tables that are designed to be adjusted in height (both raising and lowering) by the user, when there is an additional load on a table, as specified in the requirements document.

If a test cannot be carried out as specified in this standard, e.g. because a loading pad cannot be used for the application of a force due to the design of a product, the test shall be carried out as far as possible as specified.

Tables supplied with storage features shall be tested with the specified load in the storage item.

8.2 Durability of Height adjustment mechanisms

Place the table on the floor surface (5.2).

Load the table top with the specified mass applied at the positions specified in the requirements document.

Cycle the table, including any latches or activation mechanisms for the specified cycles as described below. The test device shall apply only those forces necessary to achieve the required motion and shall not add

weight to the table. The latching and/or activating mechanisms may be cycled concurrently or independently for the complete test.

First 25 % of cycles: The table shall be cycled its total vertical travel, with the load positioned at loading point A, as specified in the requirements documents.

Next 50 % of cycles: The table shall be cycled its total vertical travel, with the load positioned at loading point B, as specified in the requirements documents.

Last 25 % of cycles: The table shall be cycled its total vertical travel, with the load positioned at loading point C, as specified in the requirements documents.

One cycle shall comprise of travel from the lowest position to the highest position and return.

The cycle rate shall not exceed six cycles per minute.

The duty cycle rate for electrically driven tables includes the amount of time the drive system may be operated and the amount of time it shall not be operated to allow the drive system to cool sufficiently before it is activated again. The duty cycle shall be as recommended by the manufacturer. When the duty cycle is not recommended by the manufacturer, the duty cycle shall be “three cycles on and then off for the equivalent time it takes to run 15 cycles.”

The duty cycle may be increased when temperature control is agreed with the manufacturer.