

---

---

**Furniture — Storage units —  
Determination of strength and durability**

*Ameublement — Éléments de rangement — Détermination de la  
résistance et de la durabilité*



**PDF disclaimer**

This PDF file may contain embedded typefaces. In accordance with Adobe's licensing policy, this file may be printed or viewed but shall not be edited unless the typefaces which are embedded are licensed to and installed on the computer performing the editing. In downloading this file, parties accept therein the responsibility of not infringing Adobe's licensing policy. The ISO Central Secretariat accepts no liability in this area.

Adobe is a trademark of Adobe Systems Incorporated.

Details of the software products used to create this PDF file can be found in the General Info relative to the file; the PDF-creation parameters were optimized for printing. Every care has been taken to ensure that the file is suitable for use by ISO member bodies. In the unlikely event that a problem relating to it is found, please inform the Central Secretariat at the address given below.

© ISO 2005

All rights reserved. Unless otherwise specified, no part of this publication may be reproduced or utilized in any form or by any means, electronic or mechanical, including photocopying and microfilm, without permission in writing from either ISO at the address below or ISO's member body in the country of the requester.

ISO copyright office  
Case postale 56 • CH-1211 Geneva 20  
Tel. + 41 22 749 01 11  
Fax + 41 22 749 09 47  
E-mail [copyright@iso.org](mailto:copyright@iso.org)  
Web [www.iso.org](http://www.iso.org)

Published in Switzerland



## Contents

	Page
<b>1</b> Scope .....	<b>1</b>
<b>2</b> Normative references .....	<b>1</b>
<b>3</b> Terms and definitions .....	<b>1</b>
<b>4</b> General test conditions .....	<b>3</b>
<b>4.1</b> Preliminary preparation .....	<b>3</b>
<b>4.2</b> Test equipment .....	<b>4</b>
<b>4.3</b> Application of forces .....	<b>4</b>
<b>4.4</b> Tolerances .....	<b>4</b>
<b>4.5</b> Sequence of testing .....	<b>4</b>
<b>4.6</b> Prevention of movement during test .....	<b>4</b>
<b>4.7</b> Load on parts not subject to testing .....	<b>5</b>
<b>4.8</b> Inspection and assessment of results .....	<b>5</b>
<b>5</b> Test apparatus .....	<b>5</b>
<b>6</b> Test procedures for non-movable parts .....	<b>6</b>
<b>6.1</b> Shelves .....	<b>6</b>
<b>6.1.1</b> General .....	<b>6</b>
<b>6.1.2</b> Shelf retention test .....	<b>6</b>
<b>6.1.3</b> Deflection of shelves .....	<b>6</b>
<b>6.1.4</b> Strength of shelf supports .....	<b>6</b>
<b>6.2</b> Tops and bottoms .....	<b>8</b>
<b>6.2.1</b> Sustained load test for tops and bottoms .....	<b>8</b>
<b>6.2.2</b> Static load test for tops and bottoms .....	<b>8</b>
<b>6.3</b> Strength of clothes rails and their supports .....	<b>8</b>
<b>6.3.1</b> Strength of clothes-rail supports .....	<b>8</b>
<b>6.3.2</b> Dislodgement of clothes rails .....	<b>9</b>
<b>6.4</b> Strength of the structure .....	<b>9</b>
<b>6.4.1</b> Test for structure and underframe .....	<b>9</b>
<b>6.4.2</b> Drop test .....	<b>11</b>
<b>6.4.3</b> Tests for units with castors or wheels .....	<b>11</b>
<b>7</b> Test procedures for movable parts .....	<b>11</b>
<b>7.1</b> Pivoted doors .....	<b>11</b>
<b>7.1.1</b> General .....	<b>11</b>
<b>7.1.2</b> Strength of pivoted doors .....	<b>12</b>
<b>7.1.3</b> Slam-shut test of pivoted doors .....	<b>13</b>
<b>7.1.4</b> Durability of pivoted doors .....	<b>14</b>
<b>7.2</b> Sliding doors and horizontal roll-fronts .....	<b>15</b>
<b>7.2.1</b> General .....	<b>15</b>
<b>7.2.2</b> Slam shut/open test of sliding doors and horizontal roll-fronts .....	<b>15</b>
<b>7.2.3</b> Durability of sliding doors and horizontal roll-fronts .....	<b>15</b>



7.3	Flaps .....	17
7.3.1	Strength of bottom-hinged flaps .....	17
7.3.2	Durability of flaps .....	17
7.3.3	Drop test for top-hinged flaps .....	17
7.4	Vertical roll-fronts .....	18
7.4.1	Slam shut/open of vertical roll-fronts .....	18
7.4.2	Durability of vertical roll-fronts .....	19
7.5	Extension elements .....	19
7.5.1	General .....	19
7.5.2	Strength of extension elements .....	19
7.5.3	Durability of extension elements .....	20
7.5.4	Slam shut/open test of extension elements .....	21
7.5.5	Displacement of extension element bottoms .....	21
7.5.6	Interlock test .....	22
7.6	Locking and latching mechanism tests .....	22
7.6.1	General .....	22
7.6.2	Strength test for locking and latching mechanisms for extension elements .....	22
7.6.3	Locking and latching mechanisms for doors, flaps and roll-fronts .....	23
7.6.4	Durability test of locking and latching mechanisms .....	23
8	Units mounted to the building or other structure .....	23
8.1	Units not supported by the floor .....	23
8.1.1	General .....	23
8.1.2	Movable parts, shelf supports, tops and bottoms .....	23
8.1.3	Sustained load test (overload) .....	24
8.1.4	Dislodgement test .....	24
8.2	Units supported by the floor .....	24
9	Test report .....	24
<b>Annex A (informative) Guidance for the choice of loads, cycles, etc. for storage furniture strength and durability tests .....</b>		<b>26</b>
<b>Annex B (normative) Test apparatus for slam-shut/open test of extension elements .....</b>		<b>29</b>



## Foreword

ISO (the International Organization for Standardization) is a worldwide federation of national standards bodies (ISO member bodies). The work of preparing International Standards is normally carried out through ISO technical committees. Each member body interested in a subject for which a technical committee has been established has the right to be represented on that committee. International organizations, governmental and non-governmental, in liaison with ISO, also take part in the work. ISO collaborates closely with the International Electrotechnical Commission (IEC) on all matters of electrotechnical standardization.

International Standards are drafted in accordance with the rules given in the ISO/IEC Directives, Part 2.

The main task of technical committees is to prepare International Standards. Draft International Standards adopted by the technical committees are circulated to the member bodies for voting. Publication as an International Standard requires approval by at least 75 % of the member bodies casting a vote.

Attention is drawn to the possibility that some of the elements of this document may be the subject of patent rights. ISO shall not be held responsible for identifying any or all such patent rights.

ISO 7170 was prepared by Technical Committee ISO/TC 136, *Furniture*.

This second edition cancels and replaces the first edition (ISO 7170:1993), which has been technically revised.





# Furniture — Storage units — Determination of strength and durability

## 1 Scope

This International Standard specifies test methods for determining the strength and durability of storage units that are fully assembled and ready for use, including their movable and non-movable parts.

The tests consist of the application, to various parts of the unit, of loads, forces and velocities simulating normal functional use, as well as misuse, that might reasonably be expected to occur.

With the exception of the sustained load tests in Clause 6, the tests are designed to evaluate properties without regard to materials, design/construction or manufacturing processes.

The test results are only valid for the unit/component tested. These results may be used to represent the performance of production models provided that the tested model is representative of the production model.

Tests carried out according to this International Standard are intended to demonstrate the ability of the item to give satisfactory service in its intended environment. The tests have been developed for units/components that have not been in use. However, when properly justified, they may be used for fault investigation.

The strength and durability tests do not assess the structure of the building, e.g. the strength of wall hanging cabinets includes only the cabinet and the parts used for the attachment. The wall and the attachment into the wall are not included.

Assessment of ageing and degradation is not included.

This International Standard specifies test methods only. It does not specify requirements. These should be specified in a requirements document. If this is not available, suggested loads and cycles can be found in Annex A.

Annex B describes two apparatuses used for slam-shut and slam-open tests of extension elements.

## 2 Normative references

The following referenced documents are indispensable for the application of this document. For dated references, only the edition cited applies. For undated references, the latest edition of the referenced document (including any amendments) applies.

ISO 7619-2:2004, *Rubber, vulcanized or thermoplastic — Determination of indentation hardness — Part 2: IRHD pocket meter method*

## 3 Terms and definitions

For the purposes of this document, the following terms and definitions apply.

### 3.1

#### **catch device**

device, which keeps or pulls a component in place

NOTE It does not require a second action in order to release it, e.g. a magnetic catch or a self-closing-mechanism.



**3.2**  
**clear height**  
unobstructed height above the top of the bottom surface, e.g. the top of the extension element bottom and the lower edge of the extension element above, or the structure of the unit (see Figure 1)

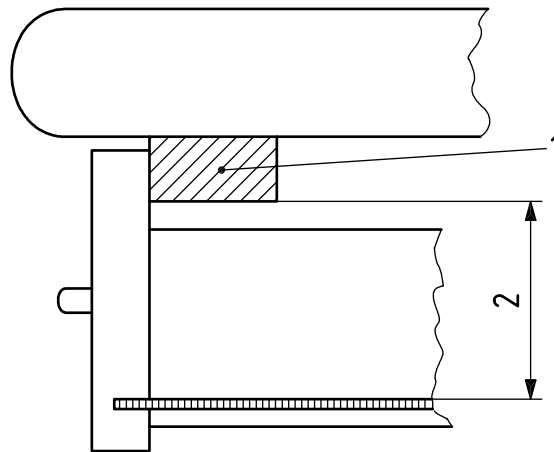

- Key**
- 1 structure of the unit
  - 2 clear height

**Figure 1 — Clear height**

**3.3**  
**damper mechanism**  
mechanism which closes the element gently

**3.4**  
**extension element**  
components that can be pulled out and pushed in

EXAMPLE Drawer, suspended pocket file, keyboard tray.

**3.5**  
**flap**  
horizontally-hinged door, which opens upwards or downwards

**3.6**  
**free standing unit**  
unit not intended to be attached to a load-bearing structure

**3.7**  
**interlock**  
device which restrains the opening of more than one extension element at a time

**3.8**  
**latching mechanism**  
mechanism which retains an extension element or a door in the closed position

NOTE It requires a second action in order to release it.





**3.9****locking mechanism**

mechanism that limits access to the interior of a unit or a storage element

NOTE It requires a key or a combination in order to activate it or to make it possible to activate it.

**3.10****stay**

hardware component usually used to hold a flap or door in the open position

**3.11****top hanging unit**

unit intended to be entirely supported by the ceiling

**3.12****wall-, panel- and screen-hanging unit**

unit intended to be supported by a wall, panel or screen

**4 General test conditions****4.1 Preliminary preparation**

The unit(s)/component(s) shall be tested as delivered. The unit(s)/component(s) shall be assembled and/or configured according to the instructions supplied with it. The most adverse configuration shall be used for each test. For testing a range of related models, only worst case(s) need to be tested. If mounting or assembly instructions are not supplied, the mounting or assembly method shall be recorded in the test report. Fittings shall be tightened before testing and shall not be re-tightened unless specifically required in the manufacturer's instructions. If the configuration must be changed to produce the worst-case conditions, this shall be recorded in the test report.

Combination of tests may be necessary to cover the properties of multifunction components; e.g. a receding door shall be tested as a sliding door and as a pivoted door.

For furniture that includes hygroscopic materials, at least one week in normal indoor conditions shall have elapsed between manufacturing (or assembly) and testing.

Except for the test for deflection of shelves (see below), the tests shall be carried out in indoor ambient conditions at a temperature between 15 °C and 25 °C. If during a test, the temperature is outside the 15 °C to 25 °C range, the maximum and/or minimum temperature shall be recorded in the test report.

The test for deflection of shelves, except metal, stone and glass shelves, shall be carried out at a relative humidity (RH) of 45 % to 55 %. If during a test, the relative humidity is outside this range, the maximum and/or minimum shall be recorded in the test report.

NOTE The 45 % to 55 % RH range and the corresponding wood moisture content is representative of average indoor conditions in Europe, USA and Canada. Other relative humidities may be appropriate in other parts of the world.

In the case of designs not addressed in the test procedures, the test shall be carried out as far as possible as described, and deviations from the test procedure recorded in the test report.

Before beginning the testing, visually inspect the unit thoroughly. Record any defects so that they are not assumed to have been caused by the tests. Carry out measurements if specified.

During testing, the unit shall be placed on the floor and levelled, unless otherwise specified.



## 4.2 Test equipment

Unless otherwise specified, the tests may be applied by any suitable device, because results are dependent only upon correctly applied forces and not on the apparatus.

The equipment shall not inhibit deformation of the unit/component, i.e. it shall be able to move so that it can follow the deformation of the unit/component during testing, so that the loads are always applied at the specified points and in the specified directions.

All loading pads shall be capable of pivoting in relation to the direction of the applied force. The pivot point shall be as close as practically possible to the load surface.

## 4.3 Application of forces

The test forces in the static load tests shall be applied sufficiently slowly to ensure that negligible dynamic force is applied. Unless otherwise specified, each specified force shall be maintained for not less than 10 s and not more than 30 s.

In durability tests, the test forces shall be applied at a rate to ensure that excessive heating does not occur. Unless otherwise specified, each test force shall be maintained for  $2\text{ s} \pm 1\text{ s}$ . If a pause is necessary, it shall be in the closed position.

Forces shall be applied in a manner which ensures normal functioning of self-closing and damping mechanisms.

The forces may be replaced by masses. The relationship  $10\text{ N} = 1\text{ kg}$  shall be used.

## 4.4 Tolerances

Unless otherwise stated, the following tolerances are applicable:

- forces:  $\pm 5\%$  of the nominal force;
- velocities:  $\pm 5\%$  of the nominal velocity;
- masses:  $\pm 1\%$  of the nominal mass;
- dimensions:  $\pm 1\text{ mm}$  of the nominal dimension;
- angles:  $\pm 2^\circ$  of the nominal angle.

The accuracy for the positioning of loading pads and impact plates shall be  $\pm 5\text{ mm}$ .

## 4.5 Sequence of testing

It is recommended that the tests be carried out in the same sequence as the clauses are numbered in this International Standard, see however 8.1.1.

If the clause sequence is not followed, the sequence shall be noted in the test report.

All tests specified for a particular component shall be carried out on the same sample.

## 4.6 Prevention of movement during test

If a freestanding unit tends to overbalance during the tests specified in Clauses 6 and 7, load the unit until this tendency stops, unless otherwise specified.

If a freestanding unit tends to slide during the tests specified in Clauses 6 and 7, with the exception of 6.4.2 and 6.4.3, the unit shall be restrained by stops (5.3).

#### 4.7 Load on parts not subject to testing

Unless otherwise specified, all storage components, other than the parts being tested, shall be uniformly loaded according to Table 1.

**Table 1 — Load on applied to parts other than the part being tested**

Part	Load <sup>a</sup>
Horizontal surfaces, shelves, door baskets, etc.	0,65 kg/dm <sup>2</sup>
Extension elements	0,2 kg/dm <sup>3</sup>
Suspended pocket files	1,5 kg/dm <sup>a</sup>
Clothes rails	2 kg/dm

<sup>a</sup> Measured perpendicular to the plane of the filing pockets.

#### 4.8 Inspection and assessment of results

After completion of each test, carry out the inspection again as specified in 4.1, after using adjustment options, if instructions are available.

Record any changes that have taken place since the initial inspection (4.1). Inspection may include measurements, e.g. opening or closing forces or deflections. The inspection shall include at least:

- the fracture of any component or joint;
- the loosening of any joint intended to be rigid, which can be demonstrated by hand pressure;
- the deformation or wear of any part or component such that its functioning is impaired;
- the loosening of any means of fixing components to the unit;
- any impaired function of unit, component or part.

### 5 Test apparatus

#### 5.1 Floor surface, a horizontal, rigid and flat surface.

For the strength test of the structure and underframe (6.4.1), the surface shall be smooth high-pressure plastics laminate.

For the drop test (6.4.2), the floor shall be faced with a 3 mm thick layer of rubber with a hardness of  $(85 \pm 10)$  IRHD, according to ISO 7619-2:2004.

#### 5.2 Wall surface, a vertical, rigid and flat surface.

**5.3 Stops**, devices to prevent the article from sliding but not tilting. They should not be higher than 12 mm, except in cases where the design of the unit necessitates the use of higher stops, in which case the lowest stop that will prevent the item from moving shall be used.

**5.4 Loading pad**, rigid disc 100 mm in diameter (or 50 mm if it is to be used in a limited space), with a flat face and a 12 mm front edge bend radius.

**5.5 Apparatus for slam shut/open of extension elements**, two apparatuses as well as calibration instructions are given in Annex B.

**5.6 Masses**, shall be designed so that they do not reinforce the structure or re-distribute the stresses.

**5.7 Glass marbles**, shall be of solid glass with 10 mm to 15 mm diameter.

They shall be in a flexible bag large enough to allow them to move in the bag during the test.



**5.8 Loads for filing pockets**, suspended filing pockets shall be loaded with typing paper or an equivalent alternative as shown in Figure 18.

**5.9 Steel impact plates**, steel plates, 200 mm in length, with one surface faced with a 3 mm thick layer of rubber with a hardness of  $(85 \pm 10)$  IRHD, according to ISO 7619-2:2004.

A range of steel plates is given in Table A.4.

## 6 Test procedures for non-movable parts

### 6.1 Shelves

#### 6.1.1 General

When shelves are structurally interconnected (other than at their ends), all the shelves shall be equally loaded.

For units with an indeterminate number of shelves, unless otherwise specified, divide the internal height of the unit, in millimetres, by 200 and take the lower integer. This number shall then be the number of shelves to be fitted.

#### 6.1.2 Shelf retention test

Apply the specified horizontal outwards force to the middle of the front edge of the shelf.

#### 6.1.3 Deflection of shelves

Testing of the deflection of shelves, which are not made of metal, glass or stone, shall be carried out in a controlled-humidity environment (see 4.1).

Place the shelf on its supports in the unit.

The deflection of the shelf shall be measured at the front edge where it is the greatest.

The deflection shall be measured to an accuracy of  $\pm 0,1$  mm with reference to a straight line parallel to the front edge drawn between two adjacent supports.

Load the shelf uniformly (see Figure 2) with the load specified and apply for:

- one hour for shelves made of metal, glass and stone;
- one week for all other shelves.

At the same points as specified above, measure and record the deflection under load to an accuracy of  $\pm 0,1$  mm and as a percentage of the distance between the supports.

Carry out the inspection and assessment according to 4.8.

#### 6.1.4 Strength of shelf supports

Load the shelf uniformly with half the load specified for 6.1.3, except at 220 mm from one support, where the impact plate (5.9) shall be tipped over 10 times over the support (see Figure 3). The striking surface of the impact plate (5.9) shall be that faced with rubber.

All supports of the shelf shall be tested.

Carry out the inspection and assessment according to 4.8.

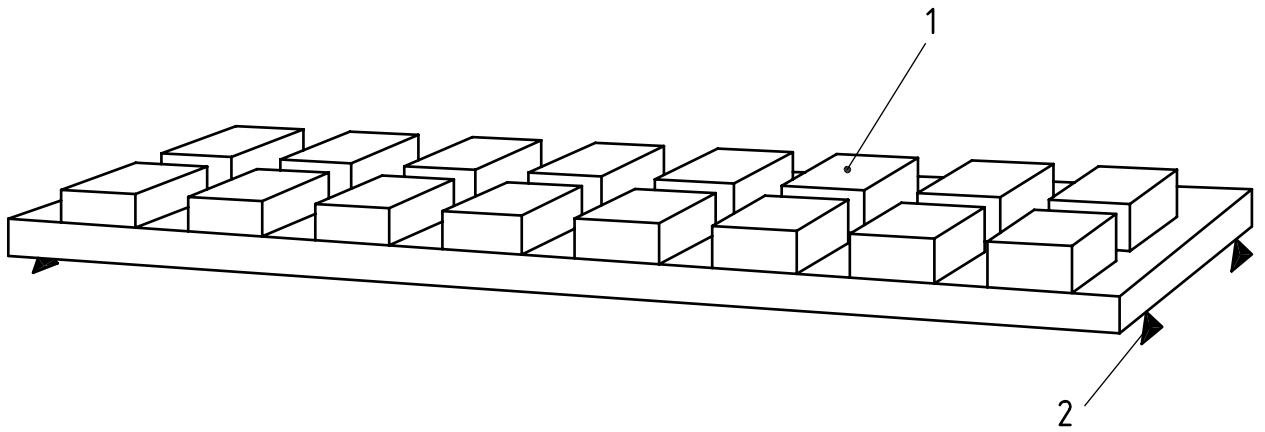

**Key**

- 1 load
- 2 shelf support

**Figure 2 — Deflection test of shelves**

Dimensions in millimetres

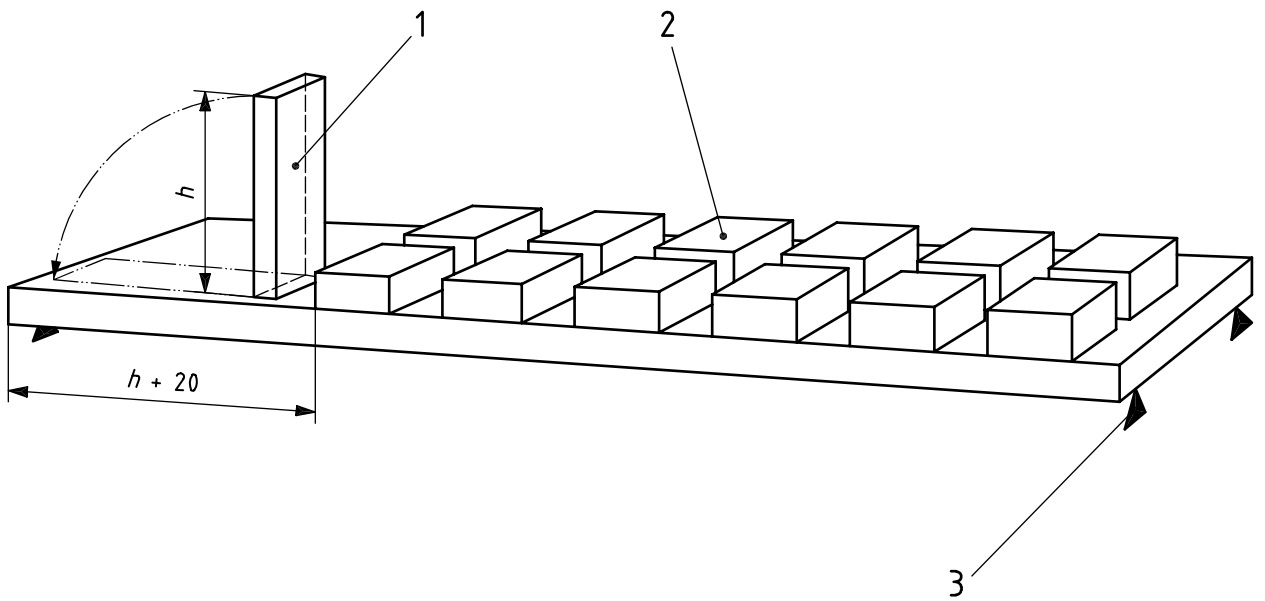

**Key**

- 1 steel impact plate
- 2 load
- 3 shelf support

**Figure 3 — Strength test of shelf supports**



## 6.2 Tops and bottoms

### 6.2.1 Sustained load test for tops and bottoms

This test is only applicable to tops which are  $\leq 1\ 000$  mm from the floor and to all bottoms.

The sustained load test of tops and bottoms shall be carried out in a controlled-humidity environment (see 4.1).

The deflection of the top or bottom shall be measured where it is the greatest.

The deflection shall be measured and recorded with reference to a straight line drawn between two adjacent supports to an accuracy of  $\pm 0,1$  mm and expressed as a percentage of the distance between the supports.

Load the top or bottom uniformly (see Figure 2) with the load specified and apply for:

- one hour for tops and bottoms made of metal, glass and stone;
- one week for all other tops and bottoms.

Measure and record the deflection under load as specified above.

### 6.2.2 Static load test for tops and bottoms

This test is only applicable to tops which are  $\leq 1\ 000$  mm from the floor and to bottoms where the clear height (3.2) is  $\geq 1\ 600$  mm.

Apply through the loading pad (5.4) a vertical downwards force 10 times at any position likely to cause failure but not less than 50 mm from the edges. If there are several such positions, apply the load 10 times to a maximum of three positions. If the top or bottom is adjustable, place it in the position most likely to result in failure.

Carry out the inspection and assessment according to 4.8.

## 6.3 Strength of clothes rails and their supports

### 6.3.1 Strength of clothes-rail supports

Place the rail on its supports in the unit.

Apply the specified load as close as possible to the weakest support [see Figure 4 a)].

If there are three or more supports [see Figure 4 b)], each support shall be loaded simultaneously with the load specified.

Carry out the inspection and assessment according to 4.8.

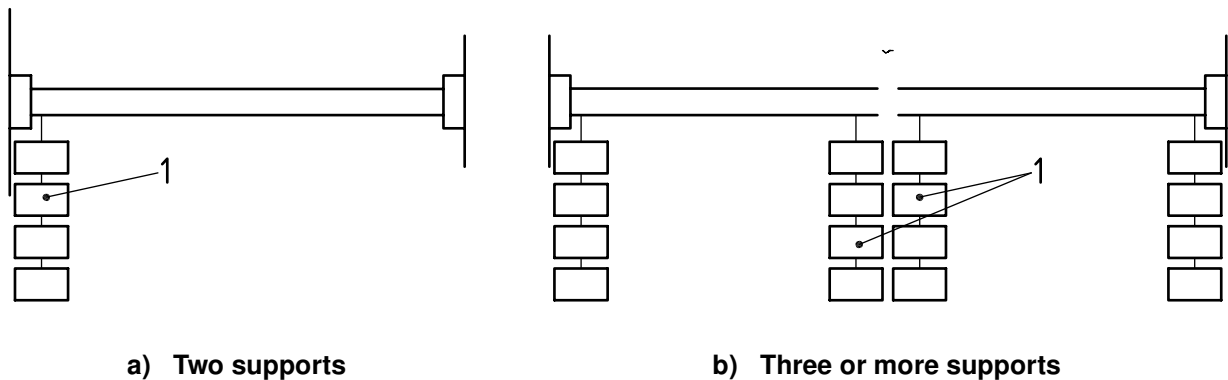
**Key**

1 load

**Figure 4 — Strength test of clothes-rail supports****6.3.2 Dislodgement of clothes rails**

Place the rail on its supports in the unit (see Figure 5).

Load the rail uniformly with the load specified and apply for:

- one hour for metal rails;
- one week for all other rails.

Carry out the inspection and assessment according to 4.8.

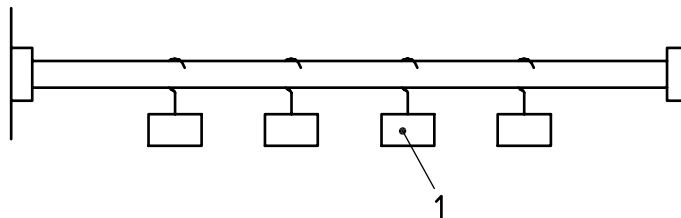
**Key**

1 load

**Figure 5 — Dislodgement of clothes rails****6.4 Strength of the structure****6.4.1 Test for structure and underframe**

This test is not applicable to units attached to another structure.

Place stops around the legs or base (see Figures 6 and 7). Levelling devices shall be opened 10 mm from the fully-closed position.

Load all parts intended for storage purposes with the load specified in Table 1. Close extension elements, flaps, roll-fronts and doors.

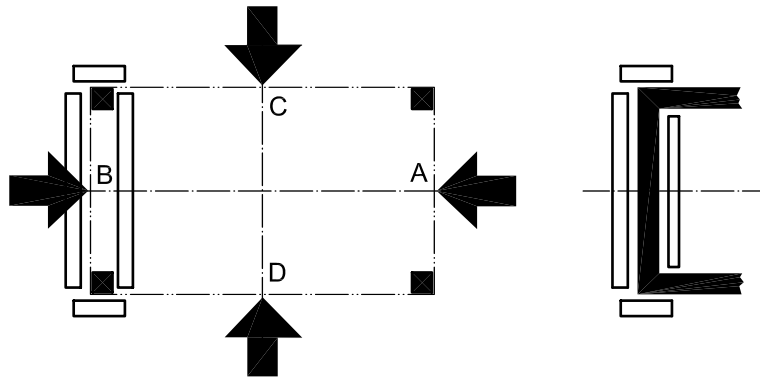

Figure 6 — Strength test of structure and underframe — Force application points (A, B, C, D) and directions

Dimensions in millimetres

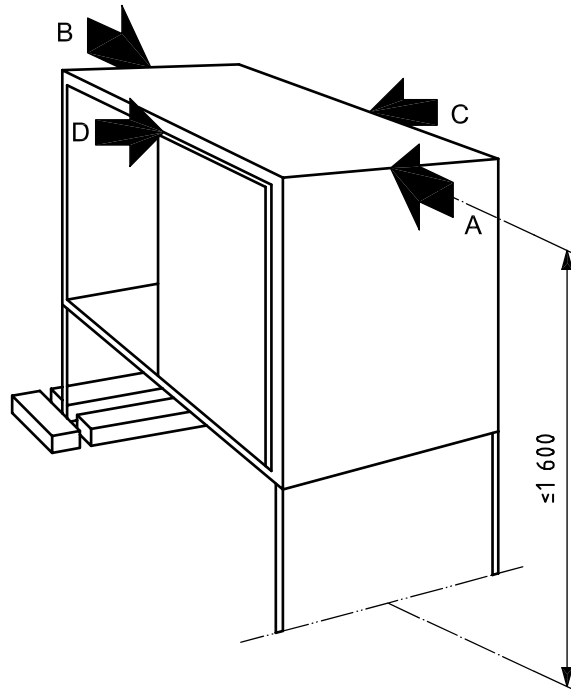

Figure 7 — Strength test of structure and underframe — Force application points (A, B, C, D)

Apply the static force specified 10 times at point A in Figure 6, on the centre line of the side of the unit as high as possible but not higher than 1 600 mm from the floor (see Figure 7). If no structural member exists at this position, apply the load by means of a rigid bar.

Repeat this procedure 10 times at points B, C and D, with the legs or base still restrained by stops.

If the unit tends to tilt, lower the force application point until tilting is just prevented. Record this height.

Carry out the inspection and assessment according to 4.8.





### 6.4.2 Drop test

The unit shall not be loaded.

Levelling devices shall be opened 10 mm from the fully-closed position.

Measure the force ( $F_1$ ), expressed in newtons, required to lift one end of the unit. Measure the force ( $F_2$ ), expressed in newtons, required to lift the other end of the unit.

Determine the drop height as a percentage of the nominal drop height as follows.

For forces ( $F$ ), expressed in newtons, to lift the end of the unit, the drop height shall be as follows.

$F \leq 200$ N	100 % of the nominal drop height
$F > 200$ N and $\leq 400$ N	$\left[ 100 - \frac{70 \times (F - 200)}{200} \right]$ % of the nominal drop height
$F > 400$ N	30 % of the nominal drop height

Lift the same end of the unit to the drop height and let it drop freely onto the floor surface (5.1). If the unit tends to overbalance at the specified drop height, lower the drop height to the point of equilibrium and record this in the test report.

Carry out the test 6 times. Height-adjustable units shall be tested 3 times at the lowest position and 3 times at the highest position.

Repeat on the opposite end.

Carry out the inspection and assessment according to 4.8.

### 6.4.3 Tests for units with castors or wheels

Apply the force at the same point as in 6.4.1, on the centre line of the side of the unit as high as possible but not higher than 1 600 mm from the floor. If no structural member exists at this position, apply the force by means of a rigid bar.

Move the unit ( $600 \pm 20$ ) mm back and forth at a rate of ( $10 \pm 2$ ) cycles per minute for the specified number of cycles. One cycle consists of a forward and a backward stroke.

Inspect the castors and the structure for damage, which could affect functioning, immediately after testing and after a recovery period of 24 h.

## 7 Test procedures for movable parts

### 7.1 Pivoted doors

#### 7.1.1 General

This test applies to all doors hinged on the vertical side, including folding doors.

Mount stops around the legs or base in order to prevent the unit from moving on the floor during the tests.

Load any storage component on the door to be tested as specified.



## 7.1.2 Strength of pivoted doors

### 7.1.2.1 Vertical load on pivoted doors

Load the door as shown in Figure 8 with the mass specified. The mass shall be suspended 100 mm from the edge furthest from the hinge.

Dimensions in millimetres

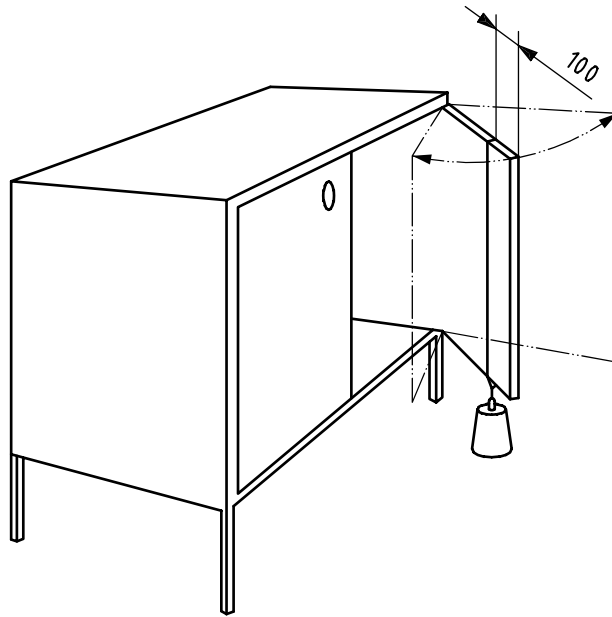

**Figure 8 — Vertical load test on pivoted doors**

Open and close the door 10 full cycles (back and forth) from a position  $45^\circ$  from fully closed to a position  $10^\circ$  from fully opened, up to a maximum of  $135^\circ$  from the fully-closed position.

Opening and closing can be done by hand using 3 s to 5 s for opening and 3 s to 5 s for closing.

Carry out the inspection and assessment without the test load according to 4.8.

### 7.1.2.2 Horizontal load on pivoted doors

Apply the horizontal static load specified perpendicular to the plane of the door on its horizontal centreline, 100 mm from the edge furthest from the hinge, as shown in Figure 9.

Carry out the test 10 times.

Carry out the inspection and assessment according to 4.8.

Dimensions in millimetres

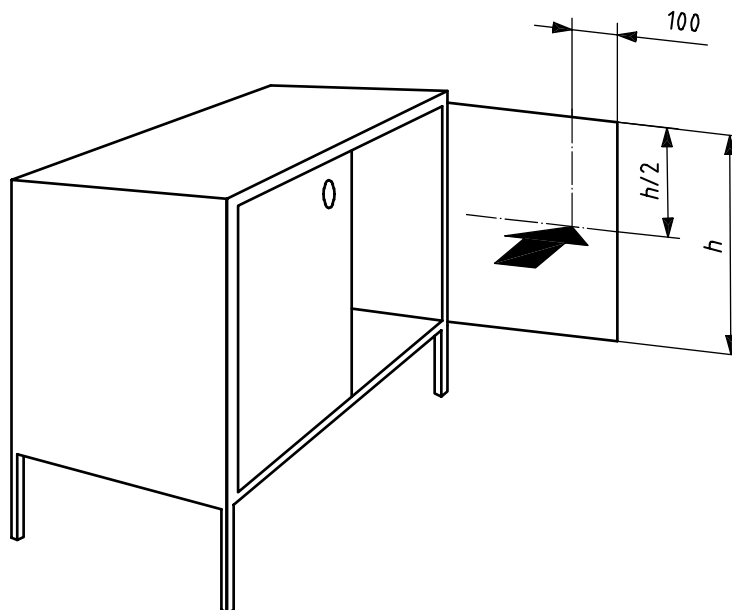

**Figure 9 — Horizontal load test on pivoted doors**

### 7.1.3 Slam-shut test of pivoted doors

This test is not applicable to pivoted doors fitted with damper mechanisms.

The door shall be closed by means of a string or cord attached to the back of the door as close as possible to the position of the centre of the handle. If the handle has a length greater than 200 mm, the string shall be attached 100 mm below the top of the handle up to a maximum height from the floor of 1 200 mm. If the door does not have a handle, the string shall be attached 25 mm from the front edge (furthest from the hinge) at the middle of the door height. The cord shall be perpendicular to the face of the door, when it is fully closed and shall not change direction by an angle greater than  $10^\circ$  during movement.

Determine the mass,  $m_1$ , required to just move the door. The test mass shall be  $m_1 + m_2$ .

Slam shut the door 10 times using the masses ( $m_1 + m_2$ ).

The test mass shall act until 10 mm before the door is fully closed. The mass shall fall through a distance of 300 mm or the distance required to close the door through  $30^\circ$ , whichever is the smaller. The test shall be carried out as shown in Figure 10.

Carry out the inspection and assessment according to 4.8.



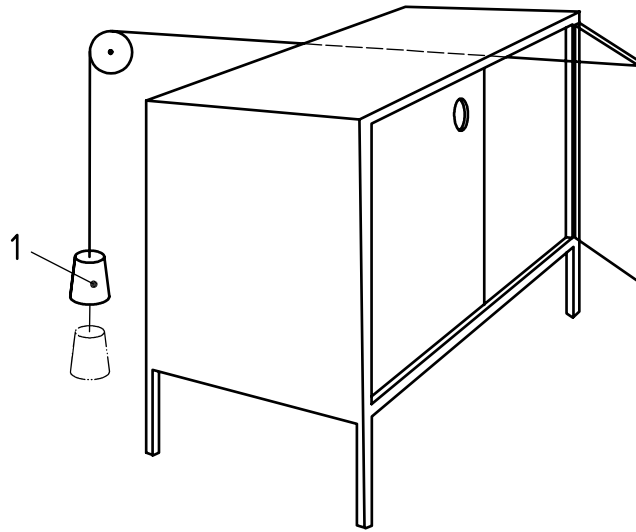

**Key**

1 mass ( $m_1 + m_2$ )

**Figure 10 — Slam-shut test of pivoted doors**

**7.1.4 Durability of pivoted doors**

Attach two masses, 1 kg each, one on each side of the door at the middle of the vertical centreline (see Figure 11).

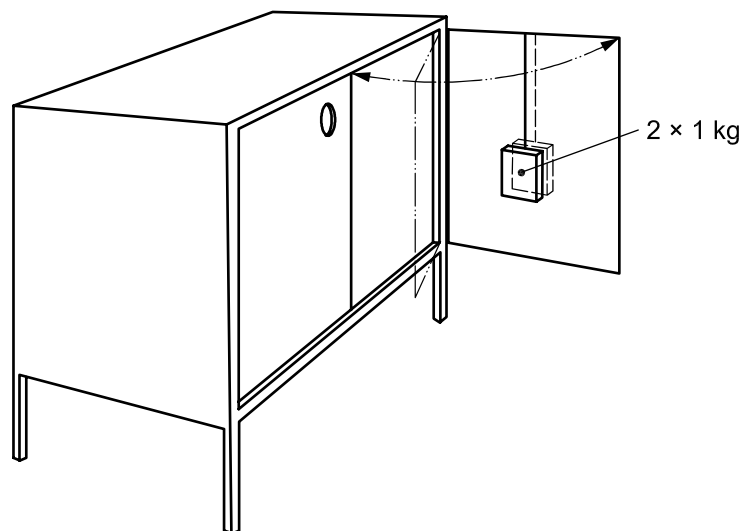

**Figure 11 — Durability test of pivoted doors**

Fully open the door to a maximum of  $130^\circ$  and close it for the number of cycles (back and forth) specified, without forcing built-in stops in the open position.

If the door has a catch device at any position, operate this mechanism at each cycle.

The door shall be gently opened and closed at each cycle using approximately 3 s for opening and 3 s for closing the door.



The recommended rate is a maximum of 6 cycles per minute.

Carry out the inspection and assessment according to 4.8.

## 7.2 Sliding doors and horizontal roll-fronts

### 7.2.1 General

This test applies to all horizontally-sliding doors, including those constructed from hinged elements.

Mount stops around the legs or base in order to prevent the unit from moving on the floor during the tests.

### 7.2.2 Slam shut/open test of sliding doors and horizontal roll-fronts

The door shall be opened/closed by means of a string or cord attached to the centre of the handle. If the handle has a length greater than 200 mm, the string shall be attached 100 mm below the top of the handle up to a maximum height from the floor of 1 200 mm. If the door does not have a handle, the string shall be attached at the middle of the door height.

Determine the mass,  $m_1$ , required to just move the door. The test mass shall be  $m_1 + m_2$ .

Close/open the door/roll-front 10 times towards the fully closed/opened positions using the masses ( $m_1 + m_2$ ).

Start the movement 300 mm from the closed/opened positions respectively. The test mass shall act until 10 mm before the door/roll-front is fully closed/opened. The test shall be carried out as shown in Figure 12.

Carry out the inspection and assessment according to 4.8.

### 7.2.3 Durability of sliding doors and horizontal roll-fronts

Open and close the door/roll-front for the number of cycles specified. The movement shall be from the fully-closed position, without forcing the stops, to a position approximately 50 mm from the fully open position (see Figure 13).

The door shall be opened/closed gently at a rate of 6 to 15 cycles per minute.

The recommended average speed is  $(0,25 \pm 0,1)$  m/s.

If the door/roll-front has a catch device at any position, operate this at each cycle.

Carry out the inspection and assessment according to 4.8.



Dimensions in millimetres

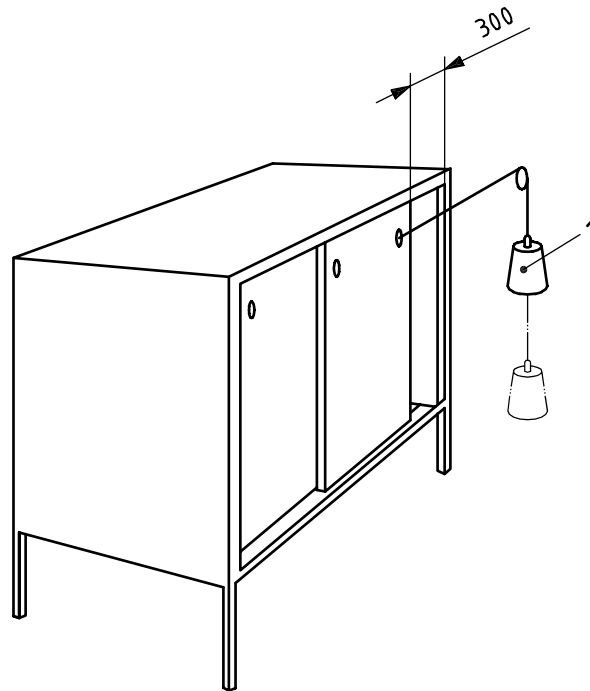

**Key**

1 mass ( $m_1 + m_2$ )

**Figure 12 — Slam shut/open test of sliding doors**

Dimensions in millimetres

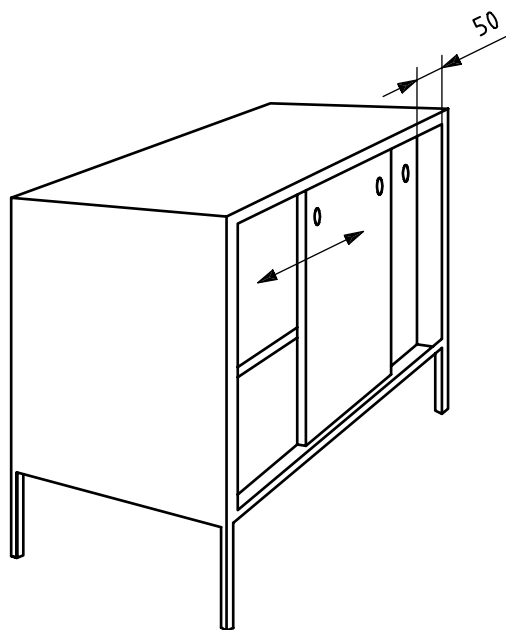

**Figure 13 — Durability of sliding doors**



## 7.3 Flaps

### 7.3.1 Strength of bottom-hinged flaps

This test only applies to flaps that can be loaded in the open position, unless the manufacturer's instructions specifically prohibit it.

With the flap in its fully opened/extended position, load with the static force specified. Apply the force 10 times, 50 mm from the weakest corner (see Figure 14).

Carry out the inspection and assessment according to 4.8.

Dimensions in millimetres

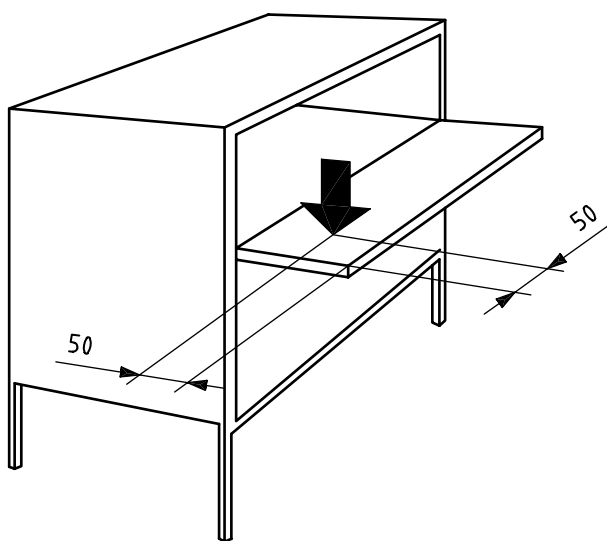

Figure 14 — Strength test of flaps

### 7.3.2 Durability of flaps

Open/close the flap for the number of cycles specified. Use approximately 3 s for opening respectively and 3 s for closing the flap.

The recommended rate is a maximum of 6 cycles per minute.

If the flap has a catch device at any position, this shall be allowed to operate at each cycle.

Self-locking stays shall be opened until just before they lock and then closed from that position.

When the flap is fitted with an adjustable friction stay, it shall be adjusted so that the flap will just open under its own weight, and be readjusted not more than 10 times during the test.

Carry out the inspection and assessment according to 4.8.

### 7.3.3 Drop test for top-hinged flaps

This test is not applicable to top-hinged flaps fitted with damper mechanisms.

Lift the door/flap until it is horizontal and allow it to drop freely for the number of cycles specified (see Figure 15).

The recommended rate is 6 cycles per minute.

Carry out the inspection and assessment according to 4.8.

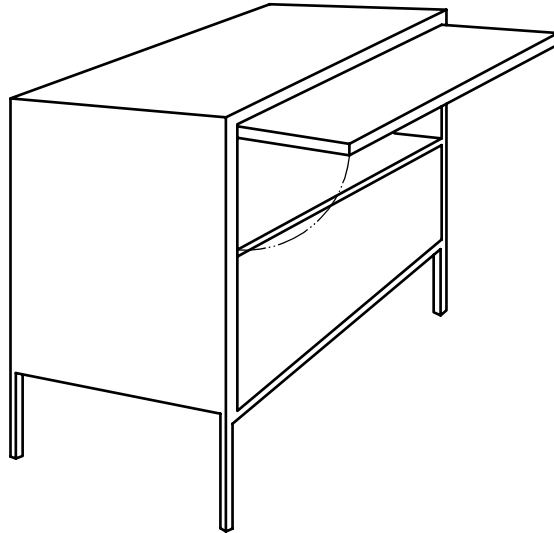

Figure 15 — Drop test for horizontally top-hinged doors/flaps

## 7.4 Vertical roll-fronts

### 7.4.1 Slam shut/open of vertical roll-fronts

Allow the roll-front to fall freely in both directions from as near the point of equilibrium as possible (see Figure 16) for the number of cycles specified. If the roll-front does not fall, the test shall be carried out according to the same principle as specified in 7.2.2 with the force applied on the vertical centreline.

Carry out the inspection and assessment according to 4.8.

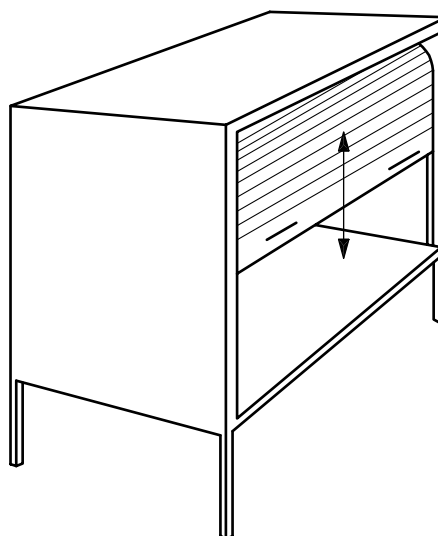

Figure 16 — Slam shut/open of roll-front



### 7.4.2 Durability of vertical roll-fronts

By means of a force applied on the vertical centreline, open and close the roll-front fully and gently at a rate of 6 to 15 cycles per minute for the number of cycles specified.

The recommended average speed is  $(0,25 \pm 0,1)$  m/s.

If the roll-front has a catch device at any position, this shall be allowed to operate at each cycle.

Carry out the inspection and assessment according to 4.8.

## 7.5 Extension elements

### 7.5.1 General

Place stops around the legs or base in order to prevent the unit from moving on the floor during the tests.

### 7.5.2 Strength of extension elements

Open the extension element to its open stops, or if there are no open stops, to the point at which one-third of the inside length (depth) of the extension element, or at least 100 mm, remains inside the unit (see Figure 17).

Apply the vertical downwards static force specified on one top corner of the extension element front.

Repeat 10 times.

Carry out the inspection and assessment according to 4.8.

Dimensions in millimetres

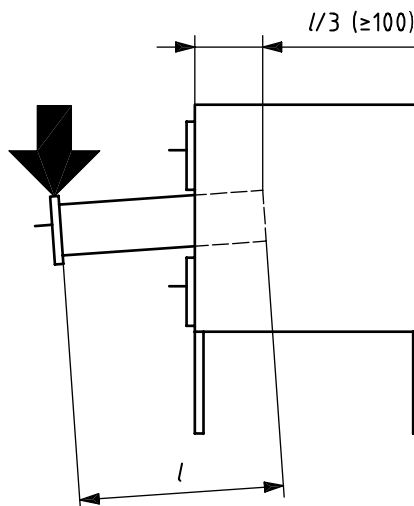
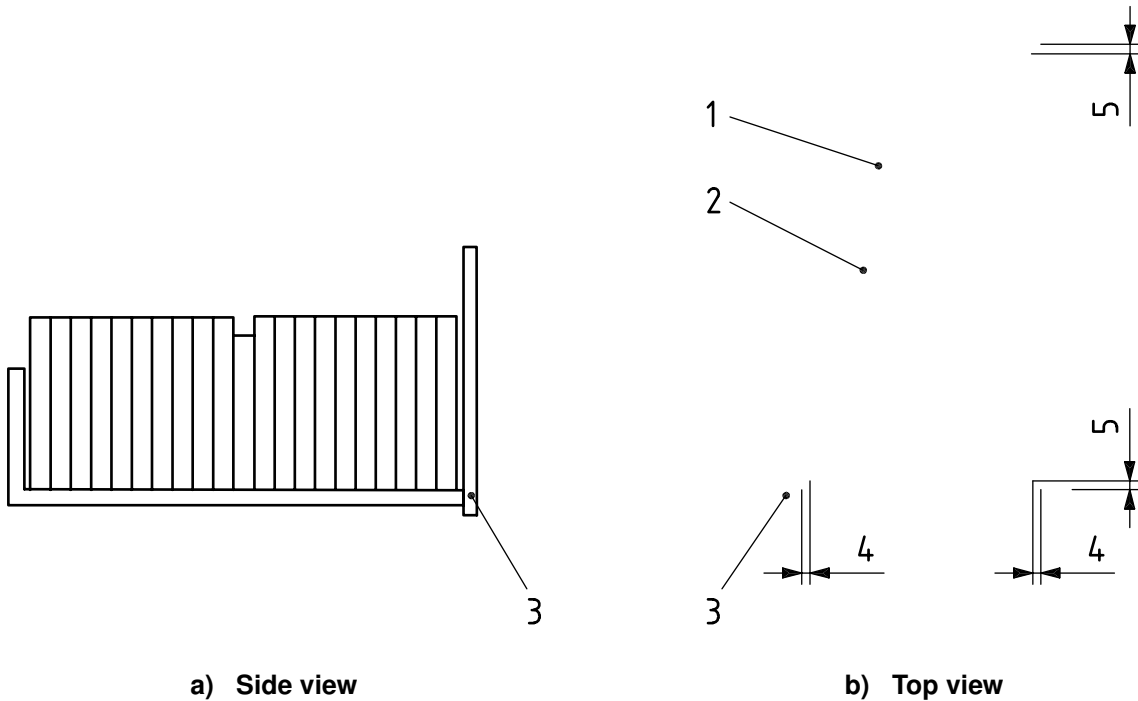

Figure 17 — Strength test of drawers and runners

7.5.3 Durability of extension elements

Load the extension element as specified. When configured for pocket files, load it uniformly with paper (5.8) as shown in Figure 18.



Key

- 1 typing paper
- 2 light weight spacing material, e.g. styrofoam
- 3 front of extension element
- 4 air gap
- 5 air gap 25 mm ± 6 mm

Figure 18 — Loading of suspended filing pockets with typing paper

Without impacting the stops, or providing vertical support, open and close the extension element gently for the number of cycles specified. Extension elements that do not have open stops shall be opened to a point at which one-third of the inside length (depth) of the extension element, or at least 100 mm, remains inside the unit (see Figure 19).

If the extension element has a catch device at any position, this shall be allowed to operate at each cycle.

The force shall be applied via the handle or, in case of two handles, in the middle between the handles. On extension elements without a handle, apply the force at the same level as the runners.

The extension element shall be opened/closed gently at a rate of 6 to 15 cycles per minute.

The recommended average speed is  $(0,25 \pm 0,1)$  m/s.



Carry out the inspection and assessment according to 4.8.

Dimensions in millimetres

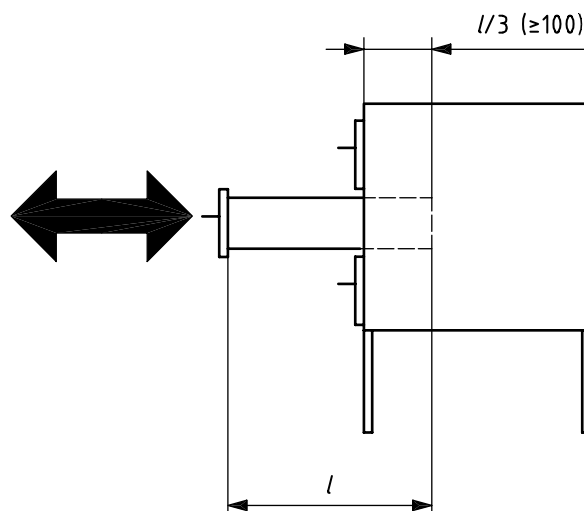

Figure 19 — Durability test of drawers and runners

#### 7.5.4 Slam shut/open test of extension elements

The slam-open part of the test is applicable only to extension elements fitted with stops in the open position.

Place the extension element on its runners and load it as specified with marbles (5.7), or, when configured for pocket files, load it with paper (5.8) as shown in Figure 18.

Open the extension element 300 mm, or fully open it if it can not be opened 300 mm. Extension elements without stops in the open position shall be opened until 100 mm remains inside the unit.

Slam shut the extension element 10 times using the velocities specified.

NOTE Two suitable slam-test apparatus are shown in Annex B.

The slamming force shall act until 10 mm before the extension element reaches its end travel.

Apply the force to the handle or, in case of two handles, in the middle between the handles. On extension elements without a handle, apply the force at the same level as the runners.

Carry out slam open according to the same principle as above, if the extension element is fitted with stops in the open position.

Carry out the inspection and assessment according to 4.8.

#### 7.5.5 Displacement of extension element bottoms

Place the extension element on its runners or suspend it in a similar way, and load it according to Table 1.

Apply a static force as specified approximately 25 mm above the bottom of the extension element, acting at the middle of the front and back of the extension element (see Figure 20).

Apply the force 10 times.

Carry out the inspection and assessment according to 4.8.

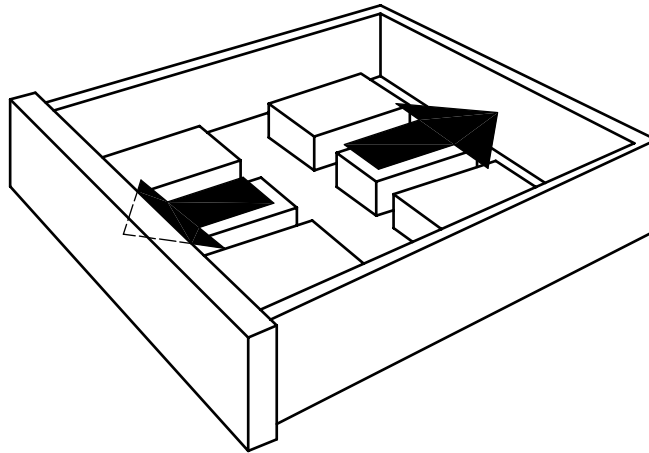

**Figure 20 — Displacement of drawer bottoms**

### 7.5.6 Interlock test

When interlocks are fitted, one extension element shall be fully extended and an outwards force as specified shall be applied to the handles of each of the remaining extension elements one at a time.

The test shall be carried out a total of 10 times on each extension element.

Record if the extension elements remain closed.

Carry out the inspection and assessment according to 4.8.

## 7.6 Locking and latching mechanism tests

### 7.6.1 General

Prevent the unit from moving during the test without interfering with the operation of the locking/latching mechanism and the furniture component being tested.

Close all doors, flaps and extension elements and lock all locking/latching mechanisms.

### 7.6.2 Strength test for locking and latching mechanisms for extension elements

Apply a force in the direction of travel of the extension element at a direction  $90^\circ$  to the front of the element and at  $30^\circ$  to that direction, upwards, downwards, to the left and to the right.

If the extension element is to be used with one specific handle or multiple handles, which are  $\leq 1/3$  of the width of the front of the extension element, the forces shall be applied at the centre of the handle(s). If no handle is fitted, apply the force to the centre of the front of the extension element. In addition, apply the forces 50 mm in from each of the left and right edges of the extension element.

If the handle is more than  $1/3$  of the width of the front of the extension element, apply the force to the centre of the handle and 50 mm from each end of the handle.

Repeat the test for each extension element.

Carry out the inspection and assessment according to 4.8.

### 7.6.3 Locking and latching mechanisms for doors, flaps and roll-fronts

Apply a force in the direction of travel of the door/flap/roll-front and at 30° to that direction, upwards and downwards.

The force shall be applied to the centre of the handle. If no handle is fitted and the position of the handle is not included in the manufacturer's instructions, the force shall be applied at the most adverse position. If the locking/latching mechanism requires rotation of the handle to operate it, the specified torque shall be applied to the handle in the direction of opening.

Repeat the test for each door.

Carry out the inspection and assessment according to 4.8.

### 7.6.4 Durability test of locking and latching mechanisms

Open and close the locking/latching mechanism for the specified number of cycles using any suitable test equipment at a rate of 6 to 15 cycles per minute.

Carry out the inspection and assessment according to 4.8.

## 8 Units mounted to the building or other structure

### 8.1 Units not supported by the floor

#### 8.1.1 General

The tests specified in this clause are intended to assess only the strength of the devices used for the mounting to the building or structure including the attachment to the unit. The tests may be carried out on a separate unit.

The unit(s) shall be mounted according to the manufacturer's installation instructions. Where the manner of mounting is not unambiguously defined, the manner of mounting shall be recorded.

Adjustable wall attachment devices, e.g. cabinet suspension brackets, shall be adjusted to the maximum depth (as far from the wall as possible) and to the middle of the height adjustment range. Distance devices/spacers used for levelling the unit shall be placed as low and as far apart as possible.

#### 8.1.2 Movable parts, shelf supports, tops and bottoms

Load the unit(s) according to Table 1 and carry out the following tests on those components most likely to cause failure to the wall attachment.

- 6.1.4: Strength of shelf supports
- 6.2.2: Static load test for tops and bottoms
- 7.1.2.1: Vertical load on pivoted doors
- 7.2.2: Slam shut/open test of sliding doors and horizontal roll-fronts
- 7.3.1: Strength of bottom-hinged flaps
- 7.4.1: Slam shut/open test of vertical roll-fronts
- 7.5.2: Strength of extension elements



### 8.1.3 Sustained load test (overload)

After carrying out the tests specified in 8.1.2, load all the storage areas with the specified load according to the following principle.

If the number of shelves is not determined by the structure of the unit(s) or specified in a requirement document, divide the internal height of the unit(s), expressed in millimetres, by 200 and take the lower integer. This number shall then be the number of shelves to be used during testing.

- Load on bottom: Specified load
- Load on first shelf: Specified load  $\times 0,6$
- Load on second shelf: Specified load  $\times 0,4$
- Load on third and following shelves: Specified load  $\times 0,25$
- Load on top surfaces: Specified load  $\times 0,2$

If the volume of the unit, calculated by the inner width, depth and height, is greater than  $0,225 \text{ m}^3$ , the total load shall be multiplied by the factor,  $R$ :

$$R = \frac{1,2}{(0,75 + 2V)}$$

where  $V$  is the volume of the unit in cubic metres,  $\text{m}^3$ .

When reduction of the load is necessary, it shall be removed from the bottom(s).

The unit shall be loaded for one week.

Check whether the unit remains attached to the structure and carries the test load.

### 8.1.4 Dislodgement test

Assemble the units according to the manufacturer's instructions. Apply to the unloaded unit the vertical upwards force specified at the least favourable point of the front edge.

Carry out the inspection and assessment according to 4.8.

## 8.2 Units supported by the floor

This test applies to units standing or resting on the floor and mounted to the building, e.g. a wall.

The unit shall be mounted according to the manufacturer's instructions.

If the manner of mounting is ambiguously defined, the manner of mounting shall be recorded in the test report.

Apply a horizontal outwards static force to the centre of the top edge of the unit.

Carry out the inspection and assessment according to 4.8.

## 9 Test report

The test report shall include at least the following information:

- a) references to this International Standard and the applied requirement document;
- b) detailed description of the piece of furniture tested;
- c) any defects observed before testing;



- d) the test results according to Clauses 6 to 8;
- e) details of any deviations from this International Standard;
- f) the name and address of the test facility;
- g) the date(s) of the test.



## Annex A (informative)

### Guidance for the choice of loads, cycles, etc. for storage furniture strength and durability tests

#### A.1 Principle

A range of loads, cycles, etc. are suggested in this annex to ensure that the standards will be of use where no requirements document is available or to assist in the development of one.

The suggested loads, cycles, etc. are intended to ensure that specifiers may gain experience in the use of strength and durability standards, in a manner which will make it possible to compare the test results with those of other specifiers. For example, without any guidance, one specifier might choose to use a 250 N strength test and a durability test of 100 000 cycles with a load of 0,6 kg/dm<sup>3</sup> to test a drawer. This would have no meaning to another specifier which had chosen to use a 400 N strength test and a durability test of 50 000 cycles with a load of 0,4 kg/dm<sup>3</sup>.

The suggested loads, cycles, etc. should be sufficient to cover not only the full range of domestic and contract applications but also the differences which will exist in the manner in which furniture is used in different applications. It should be noted that the loads and cycles which are appropriate to testing, e.g. the loads and cycles applied to a filing cabinet drawer for general office use may be different from the loads and cycles that would be appropriate to a filing cabinet drawer for use in a hospital, bank or home office.

It shall be emphasized that test methods for activities affecting the safety of storage furniture, have not been pre-selected from the range of strength and durability tests. If required they should be determined by the specifier, because the requirements for safety may be different from the requirements for serviceability.

The suggested ranges of loads, cycles, etc. are provided to allow specifiers the freedom to carry out the tests in the manner they consider preferable. It is not intended that the tests be carried out at the lowest test level and carried on, increasing in severity until failure occurs, nor that tests should be carried out at a pre-determined column, based on the application for which the furniture is intended.

The requirements must be determined by the specifier. The requirements used in other furniture standards include:

- no failure as listed in 4.8;
- no failure affecting the safe use of the product;
- no failure affecting function or appearance;
- no failure according to 4.8 up to a specified limit, after that no failure affecting safety.

It is emphasized that the application of this International Standard is only useful if the requirements truly represent the service environment for which the furniture is intended. Requirements which are too severe or insufficiently severe render the results of the testing valueless.

#### A.2 Test tables

See Tables A.1 to A.4.





Table A.1 — Strength tests — Suggested loads, forces, etc

Clause/Test	Unit	Suggested loads and forces <sup>a</sup>			
		1	2	3	Increment for further steps
6.1.2 Shelf retention test	N	50 % of the weight of the unloaded shelf			Not recommended
6.1.3 Deflection of shelves <sup>b</sup>	kg/dm <sup>2</sup>	1	1,5	2	+0,5
6.1.4 Strength of shelf supports (see Table A.4)	kg	1,1	1,7	2,5	Not recommended
6.2.1 Sustained load test for tops and bottoms <sup>b</sup>	kg/dm <sup>2</sup>	1	1,5	2	+0,5
6.2.2 Static load test for tops and bottoms	N	600	750	1 000	250
6.3.1 Strength of clothes-rail supports	kg/dm	4	4	5	Not recommended
6.3.2 Dislodgement of clothes rails	kg/dm	4	4	5	Not recommended
6.4.1 Test for structure and underframe	N	200	300	450	150
6.4.2 Drop test	mm	—	50	100	50
7.1.2.1 Vertical load on pivoted doors	kg	10	20	30	10
7.1.2.2 Horizontal load on pivoted doors	N	50	60	70	10
7.1.3 Slam-shut test of pivoted doors	$m_2$ , kg	2	3	4	1
7.2.2 Slam shut/open test of sliding doors and horizontal roll-fronts	$m_2$ , kg	2	3	4	1
7.3.1 Strength of bottom-hinged flaps	N	150	200	250	50
7.3.3 Drop test for top-hinged flaps	Cycles	125	250	500	Multiply by 2
7.4.1 Slam shut/open of vertical roll-fronts (only for roll-fronts not falling under own weight)	$m_2$ , kg	2	3	4	1
7.5.2 Strength of extension elements	N	100	200	300	100
7.5.4 Slam shut/open test of extension elements (velocity of calibration extension element in m/s)	5 kg	1,1	1,3	1,4	0,1
	35 kg	0,8	1,0	1,1	0,1
	factor $K$	1,6	2,5	2,9	See B.3
7.5.5 Displacement of extension element bottoms	N	40	60	70	Not recommended
7.5.6 Interlock test	N	200	200	200	Not recommended
7.6.2 Strength test for locking and latching mechanisms for extension elements, and 7.6.3 Locking and latching mechanisms for doors, flaps and roll-fronts	N	200	200	200	Not recommended
8.1.3 Sustained load test (overload)	kg/dm <sup>2</sup>	2	2,5	3	0,5
8.1.4 Dislodgement test	N	Not applicable	100	200	200
8.2 Units supported by the floor	N	200	200	200	Not recommended

<sup>a</sup> The suggested loads, forces etc. shown in columns 1, 2 and 3 are considered to be suitable for storage furniture for most fields of application from domestic to contract use. The increments shown in the last column are suggested for storage furniture only for special applications, where higher loads and forces may be required.

<sup>b</sup> The specifier should specify the maximum acceptable deflection. The deflection should be described as a percentage of the items' length.



**Table A.2 — Durability tests - Suggested cycles**

Clause/Test	Suggested cycles <sup>a</sup>			
	1	2	3	Increment for further steps
6.4.3 Tests for units with castors or wheels	500	1 000	2 000	All rows: Multiply previous column by 2
7.1.4 Durability of pivoted doors	20 000	40 000	80 000	
7.2.3 Durability of sliding doors and horizontal roll-fronts	10 000	20 000	40 000	
7.3.2 Durability of flaps	5 000	10 000	20 000	
7.4.2 Durability of vertical roll-fronts	5 000	10 000	20 000	
7.5.3 Durability of extension elements	20 000	40 000	80 000	
7.6.4 Durability test of locking and latching mechanisms	2 500	5 000	10 000	

<sup>a</sup> The suggested cycles shown in columns 1, 2 and 3 are considered to be suitable for storage furniture for most fields of application from domestic to contract use. The increments shown in the last column are suggested for storage furniture for special applications, where a higher number of cycles may be required.

**Table A.3 — Suggested loads in storage components for tests in Tables A.1 and A.2**

Component	Unit	Suggested load			
		1	2	3	Increment for further steps
Door baskets	kg/dm <sup>2</sup>	1	1,5	2	+0,5
Extension elements <sup>a</sup>	kg/dm <sup>3</sup>	0,2	0,35	0,5	0,15
Suspended pocket files	kg/dm length	2,0	3,0	4,0	Not recommended

<sup>a</sup> The volume of extension elements is calculated from the internal depth × internal width × internal clear height.

**Table A.4 — Suggested impact plates<sup>a</sup> for testing strength of shelf supports**

Plate parameter	Unit	Suggested mass		
		Plate no. 1	Plate no. 2	Plate no. 3
Mass (excluding rubber)	kg	1,1	1,7	2,5
Approximate width	mm	70	109	160
Approximate thickness	mm	10	10	10
Length	mm	200	200	200

<sup>a</sup> The impact plates shall be faced with a 3 mm thick layer of rubber with a hardness of (85 ± 10) IRHD according to ISO 7619-2:2004.



## Annex B (normative)

### Test apparatus for slam-shut/open test of extension elements

#### B.1 Principle

Lightweight (empty) extension elements are slammed at consistently higher speeds than heavy (full) extension elements, but friction does not significantly affect the slamming speed.

Standard “empty” (5 kg) and “full” (35 kg) extension elements with minimal friction are used to simulate these conditions. Using these reference, extension elements, the speed of the extension element slamming apparatus is adjusted to the slamming velocities specified.

#### B.2 Test apparatus

The following two types of apparatus are recommended for the slam shut/open test of extension elements:

**B.2.1 Pneumatic slamming apparatus**, consisting of a pneumatically actuated low-friction piston/cylinder with a means of regulating the pressure of air supplied from a reservoir.

The air-flow between the piston/cylinder and the reservoir is controlled by an air-operated valve which allows the air stored in the reservoir to be connected to the piston/cylinder rapidly, when the control valve is operated. The rate of flow is controlled by the incorporation of connecting tubing of appropriate internal diameters and lengths (see Figure B.1).

#### B.2.2 Slamming apparatus with weight and string or cord

The extension element shall be shut/opened by a hanging weight of mass  $m$  that is attached to the extension element by means of a string or cord. The force exerted by the weight is removed 10 mm before the extension element reaches its endstops. The movement is started 300 mm from the fully-opened position (see Figure B.2).

#### B.3 Calibration

##### B.3.1 Pneumatic slamming apparatus

Using two reference extension elements, having masses of 5 kg and 35 kg, respectively and exhibiting a total frictional force in the runners of not greater than 10 N, calibrate the apparatus to produce the closing and opening velocities specified in Table A.1. This can be achieved by adjusting the pressure to produce the calibration velocity for the reference extension element of 35 kg. Then the tube length from the pressure regulator (see Figure B.1) is adjusted to produce the calibration velocity for the reference extension element of 5 kg.



### B.3.2 Slamming apparatus with weight and string

The hanging-weight mass,  $m$ , is calculated by using the following formula:

$$m = K \cdot \sqrt[3]{M}$$

where

$M$  is the total mass of the extension element;

$K$  is specified in Table A.1.

Using the values for  $K$  given in Table A.1, the slam velocities after a travel distance of 300 mm will be equal to the slam velocities exerted by the pneumatic slamming apparatus.

For other extension element travel distances to other calibration conditions than those specified in Table A.1, the factor  $K$  shall be determined by experiments to allow for comparison with the pneumatic slamming apparatus.

## B.4 Procedure

### B.4.1 Slam-shut test

Open the extension element to a maximum of 300 mm or to a point at which one third of the inside length (depth) of the extension element or at least 100 mm, remains in the furniture (see Figure B.3).

Slam shut the extension element from that position.

### B.4.2 Slam-open test

This test only applies to extension elements with end stops in the open position.

Close the extension element to 300 mm before the fully open position is reached, or close it completely, if the travel length of the extension element is less than 300 mm (see Figure B.2).

Slam open the extension element from that position.

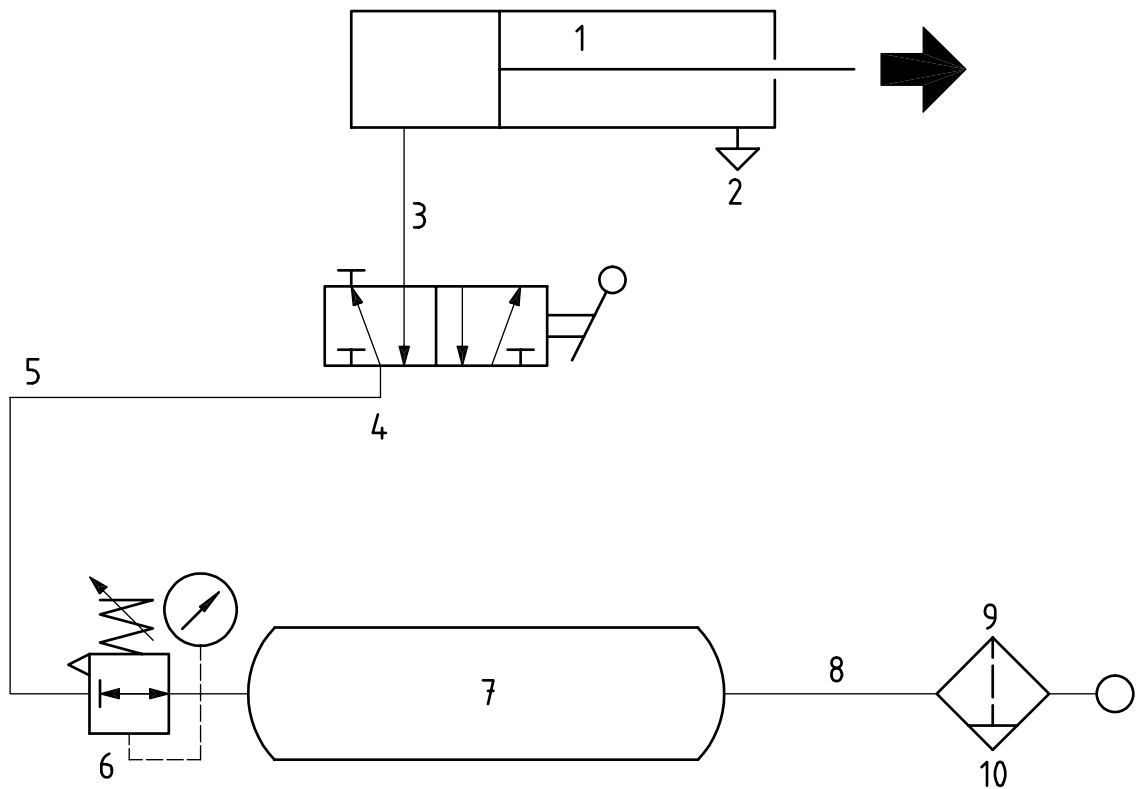

**Key**

- 1 cylinder  $\varnothing$  40 mm, stroke  $\leq$  300 mm
- 2 free outlet
- 3 valve to be mounted directly on cylinder
- 4 valve 1/4 inch. Nominal air flow  $>$  900 l/min
- 5 tube length 720 mm, internal diameter 6
- 6 pressure regulator. Nominal air flow  $>$  900 l/min
- 7 air reservoir ( $\varnothing = 75$  mm,  $L = 350$  mm,  $V = 1\,545,6$  cm<sup>3</sup>)
- 8 tube length 1 040 mm, internal diameter 3
- 9 air cleaner
- 10 primary pressure 6 bar

**Figure B.1 — Circuit diagram for pneumatic drawer-slammng apparatus**



Dimensions in millimetres

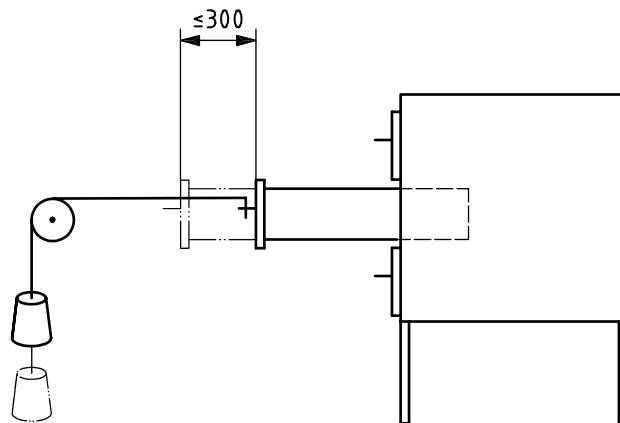

Figure B.2 — Slam-open test of extension element

Dimensions in millimetres

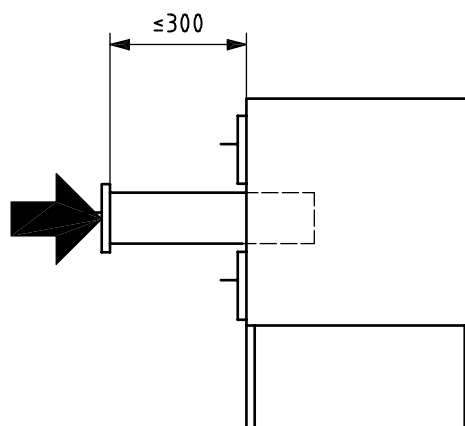

Figure B.3 — Slam-shut test of extension element





