

MODEL HIPA08181333

8-18GHz Broadband Power Amplifier

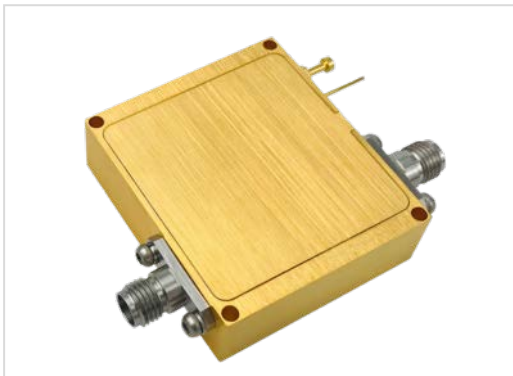

Note: The photo is for illustration purposes only.
Please refer to outline drawing

■ Features

- Ultra Wide Band: 8-18GHz
- Gain: 15dB
- Output Power Psat: 34dBm
- Bias: Vd=12V;Id=2A

■ Applications

- Radar Systems
- Communication Systems
- Receivers Systems

□ Electrical Specifications

Parameter	Min.	Typ.	Max	Units
Frequency Range	8-18			GHz
Small Signal Gain	13			dB
Gain Flatness		±1.0	±1.1	dB
Input VSWR		1.8	2.5	-
Output VSWR		1.8	2.5	-
Output Power for 1 dB Compression (P1dB)	33			dBm
Saturated Output Power (Psat)		34		dBm
Input Max Power(no damage)			25	dBm
DC Current (Vcc=12V) (@Pout=2W)		2		A
Impedance	50			Ω
Input Output Connector	SMA			
Material	Aluminium/Gold Painting			
Weight	80g			
Dimension	-			

Environmental Conditions

Operational Temperature	-45°C~+85°C	Vibration	25g rms (15 degree 2KHz) endurance, 1 hour per axis
Storage Temperature	-55°C~+125°C	Shock	20G for 11msc half sin wave, 3 axis both directions
Executive Standard	MIL-STD-810G	Humidity	100% RH at 35c, 95%RH at 40°C

Absolute Maximum Ratings

Supply Bias Voltage	+15V
RF INPUT POWER	25dBm
ESD sensitivity (HBm)	Class 0, passed 150V

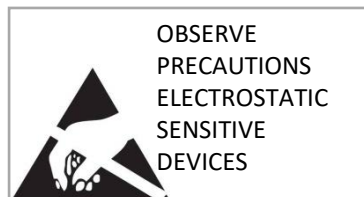

Outline Drawing

All Dimensions in mm (inches) Tolerance ± 0.25 (0.01)

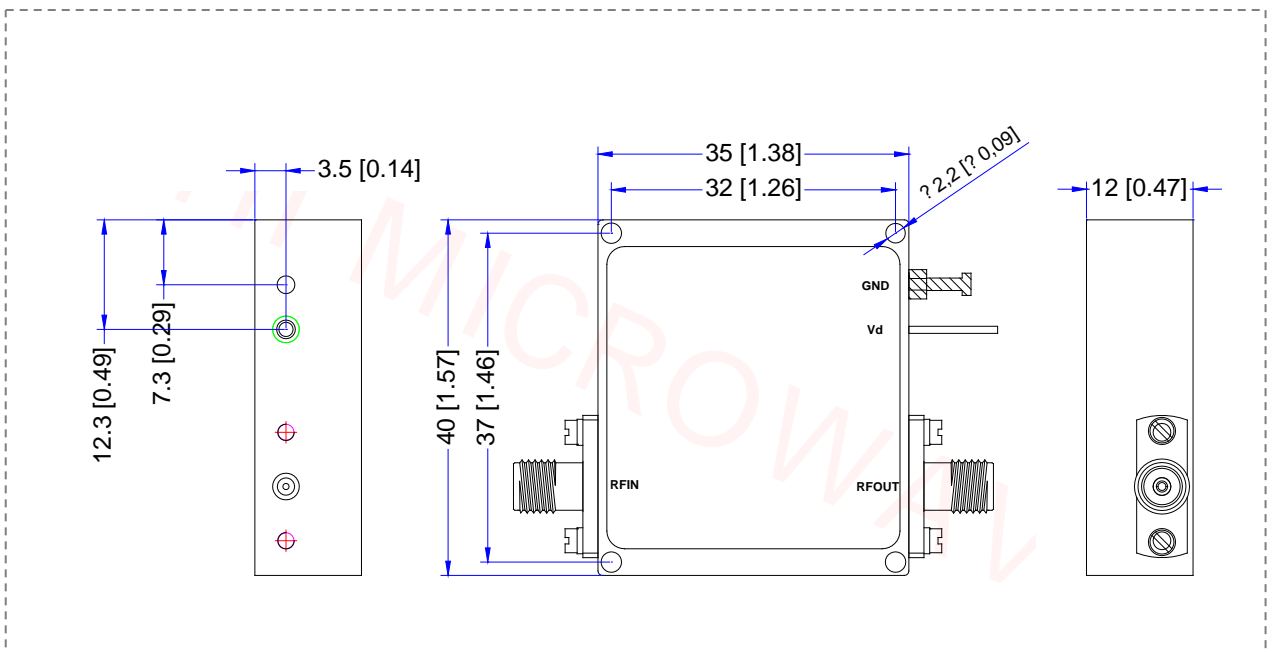

*****Heat Sink required during operation*****