



Note: The photo is for illustration purposes only.  
Please refer to outline drawing

### ■ Features

- Ultra Wide Band: 12-18GHz
- Gain: 35dB
- Output Power Psat: 32dBm
- Bias: Vd=12V;Id=2A

### ■ Applications

- Radar Systems
- Communication Systems
- Receivers Systems

### □ Electrical Specifications

Parameter	Min.	Typ.	Max	Units
Frequency Range	12-18			GHz
Small Signal Gain	33	36		dB
Gain Flatness		± 1.5		dB
Input VSWR		1.8		-
Output VSWR		1.8		-
Output Power for 1 dB Compression (P1dB)	30			dBm
Saturated Output Power (Psat)		31		dBm
Input Max Power(no damage)			10	dBm
DC Current (Vcc=12V) (@Pout=2W)		1.5	2	A
Impedance	50			Ω
Input Output Connector	SMA-K			
Material	Aluminium/Gold Painting			
Weight	-			
Dimension	With Heatsink			

### Environmental Conditions

<b>Operational Temperature</b>	-45°C~+85°C	<b>Vibration</b>	25g rms (15 degree 2KHz) endurance, 1 hour per axis
<b>Storage Temperature</b>	-55°C~+125°C	<b>Shock</b>	20G for 11msc half sin wave, 3 axis both directions
<b>Executive Standard</b>	MIL-STD-810G	<b>Humidity</b>	100% RH at 35c, 95%RH at 40°C

### Absolute Maximum Ratings

<b>Supply Bias Voltage</b>	+13V
<b>RF INPUT POWER</b>	10dBm
<b>ESD sensitivity (HBm)</b>	Class 0, passed 150V



OBSERVE  
PRECAUTIONS  
ELECTROSTATIC  
SENSITIVE  
DEVICES



### Outline Drawing

All Dimensions in mm ( inches ) Tolerance  $\pm 0.25$  ( 0.01 )

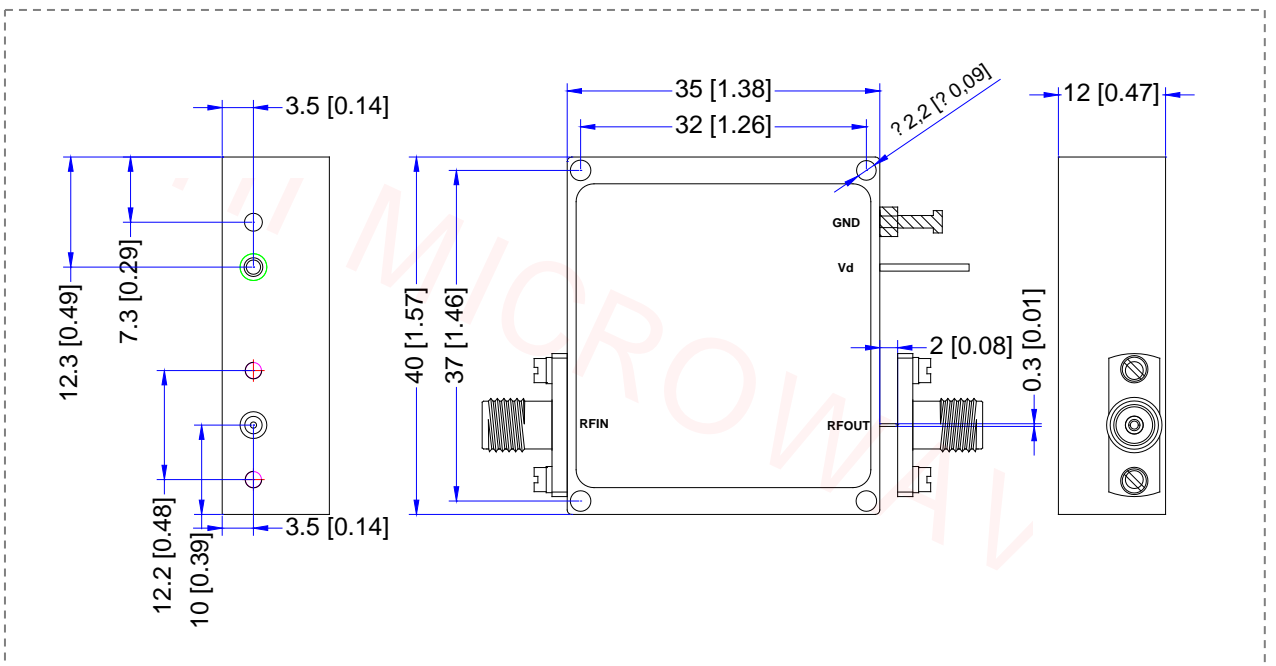

**\*\*\*Heat Sink required during operation\*\*\***