

MODEL HIPA26283840

26-28GHz Broadband Power Amplifier



Note: The photo is for illustration purposes only.
Please refer to outline drawing

■ Features

- Ultra Wide Band: 26-28GHz
- Gain: 40dB
- Output Power Psat: 41dBm
- Bias: Vd=12V;Id=6A

■ Applications

- Radar Systems
- Communication Systems
- Receivers Systems

□ Electrical Specifications

Parameter	Min.	Typ.	Max	Units
Frequency Range	26-28			GHz
Small Signal Gain	35	38		dB
Gain Flatness		±2		dB
Input VSWR		2.0		-
Output Power for 1 dB Compression (P1dB)	40	40.5		dBm
Saturated Output Power (Psat)		41		dBm
Input Max Power(no damage)			5	dBm
Internally Generated Spurious		-60		dBc
DC Current (Vcc=+12V) (@Pout=10W)		6	10	A
Impedance	50			Ω
Input Output Connector	2.92-k			
Material	Aluminium			
Weight	-			
Dimension	180mmX152mmX34mm			

Environmental Conditions

Operational Temperature	-45°C~+85°C	Vibration	25g rms (15 degree 2KHz) endurance, 1 hour per axis
Storage Temperature	-55°C~+125°C	Shock	20G for 11msc half sin wave, 3 axis both directions
Executive Standard	MIL-STD-810G	Humidity	100% RH at 35c, 95%RH at 40°C

Absolute Maximum Ratings

Supply Bias Voltage	+15V
RF INPUT POWER	+5dBm
ESD sensitivity (HBm)	Class 0, passed 150V

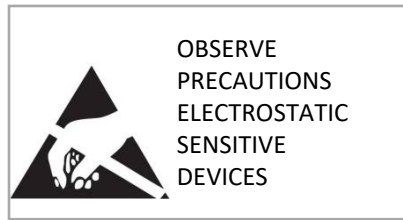

Outline Drawing

All Dimensions in mm (inches) Tolerance ± 0.25 (0.01)

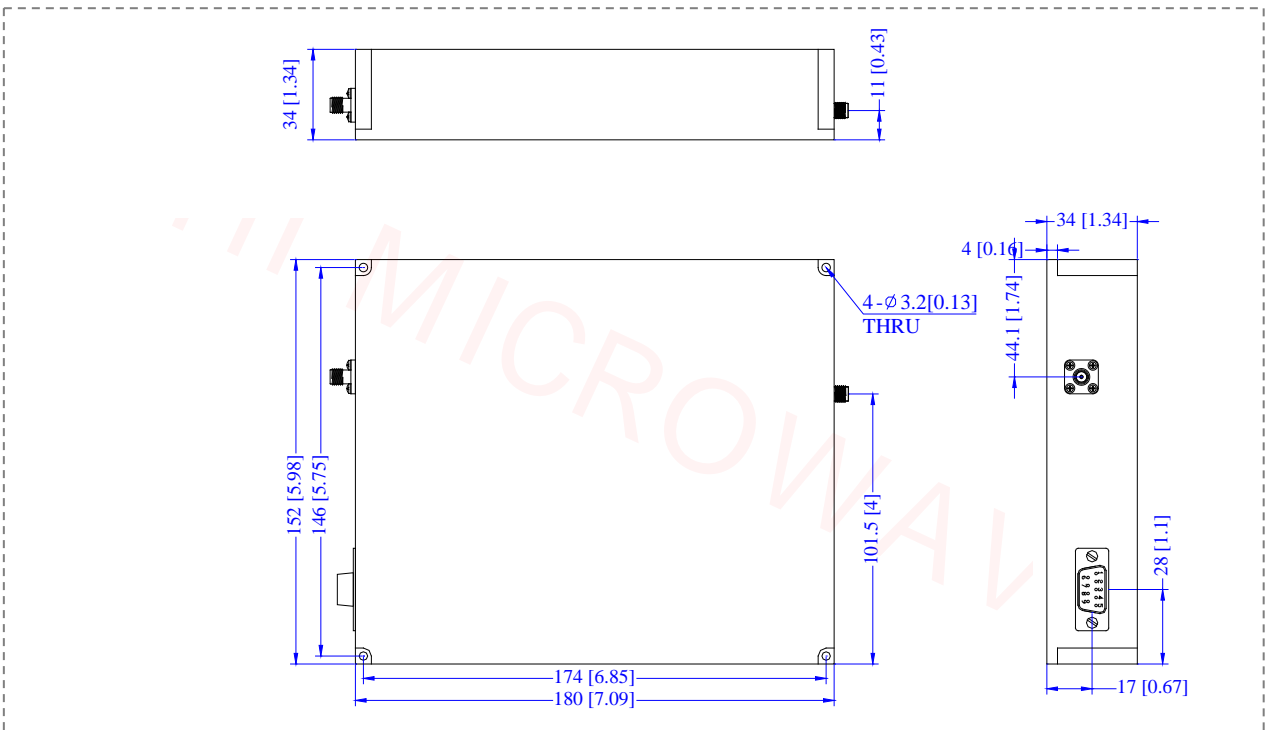

*****Heat Sink required during operation*****