

MODEL HILNAH1064540

0.01-6GHz Broadband Amplifier



Note: The photo is for illustration purposes only. Please refer to outline drawing

■ Features

- Ultra Wide Band: 0.01-6GHz
- Gain: 45dB
- Output Power: 18dBm
- High Output IP3: 25dBm

■ Applications

- Radar Systems
- Communication Systems
- Receivers Systems

□ Electrical Specifications

Parameter	Min.	Typ.	Max	Units
Frequency Range	0.01-6			GHz
Gain	42	45		dB
Gain Flatness		±1.5	±2	dB
Input VSWR		10		dB
Output VSWR		10		dB
Output Power for (P1dB)	15	17		dBm
Output Power Past		18		dBm
Noise Figure		4	5	dB
Output IP3		25		dBm
Input Max Power(no damage)			-25	dBm
DC Current (Vcc=+12V)		250		mA
Impedance	50			Ω
Input Output Connector	SMA-k			
Material	Aluminium\Gold Painting			
Weight	50g			
Package Sealing	General Sealing (Standard)			

Environmental Conditions

Operational Temperature	-45°C~+85°C	Vibration	25g rms (15 degree 2KHz) endurance, 1 hour per axis
Storage Temperature	-55°C~+125°C	Shock	20G for 11msc half sin wave, 3 axis both directions
Executive Standard	MIL-STD-810G	Humidity	100% RH at 35c, 95%RH at 40°C

Absolute Maximum Ratings

Supply Bias Voltage	+15V
RF INPUT POWER	-25dBm
ESD sensitivity (HBm)	Class 0, passed 150V



Outline Drawing

All Dimensions in mm (inches) Tolerance ± 0.25 (0.01)

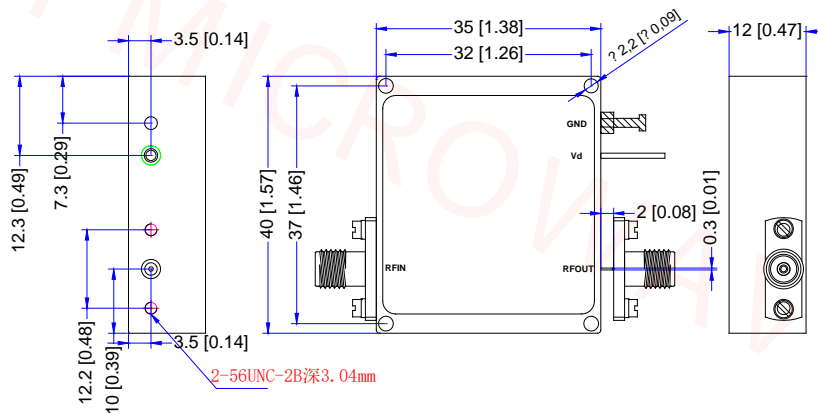

*****Heat Sink required during operation*****