

MODEL HILNAT1183030

0.1-18GHz Broadband Amplifier



Note: The photo is for illustration purposes only.
Please refer to outline drawing

■ Features

- Ultra Broadband: 0.1~18GHz
- Low Noise Figure: 3dB
- High Gain: 30dB
- P1dB Output Power: 15dBm
- High OIP3: 25dBm
- Supply Voltage : +12V@ 250mA

■ Applications

- Radar Systems
- Communication Systems
- Receiving Systems

□ Electrical Specifications

Parameter	Min.	Typ.	Max.	Units
Frequency Range	0.1-18			GHz
Gain	30			dB
Gain Flatness		± 1	± 2	dB
Input VSWR		1.8	2.3	-
Output VSWR		1.8	2.3	-
Output Power for 1 dB Compression (P1dB)	10	15		dBm
Noise Figure		3		dB
OIP3		25		dBm
Input Max Power(no damage)			-10	dBm
DC Current (Vcc=+12~15V)		250		mA
Weight	50			g
Impedance	50			Ω
Input Connector	SMA-K(Removable)			
Output Connector	SMA-K(Removable)			
Material	Aluminum Gold Plating			
Package Sealing	General Sealing (Standard); Hermetically Seal(Optional)			

Environmental Conditions

Operational Temperature	-45°C~+85°C	Vibration	25g rms (15 degree 2KHz) endurance, 1 hour per axis
Storage Temperature	-55°C~+125°C	Shock	20G for 11msec half sin wave,3 axis both directions
Executive Standard	MIL-STD-810G	Humidity	100% RH at 35c, 95%RH at 40°C

Absolute Maximum Ratings

Supply Bias Voltage	+15V
RF INPUT POWER	-10dBm
ESD sensitivity (HBm)	Class 0, passed 150V



Outline Drawing

All Dimensions in mm (inches) Tolerance ± 0.25 (0.01)

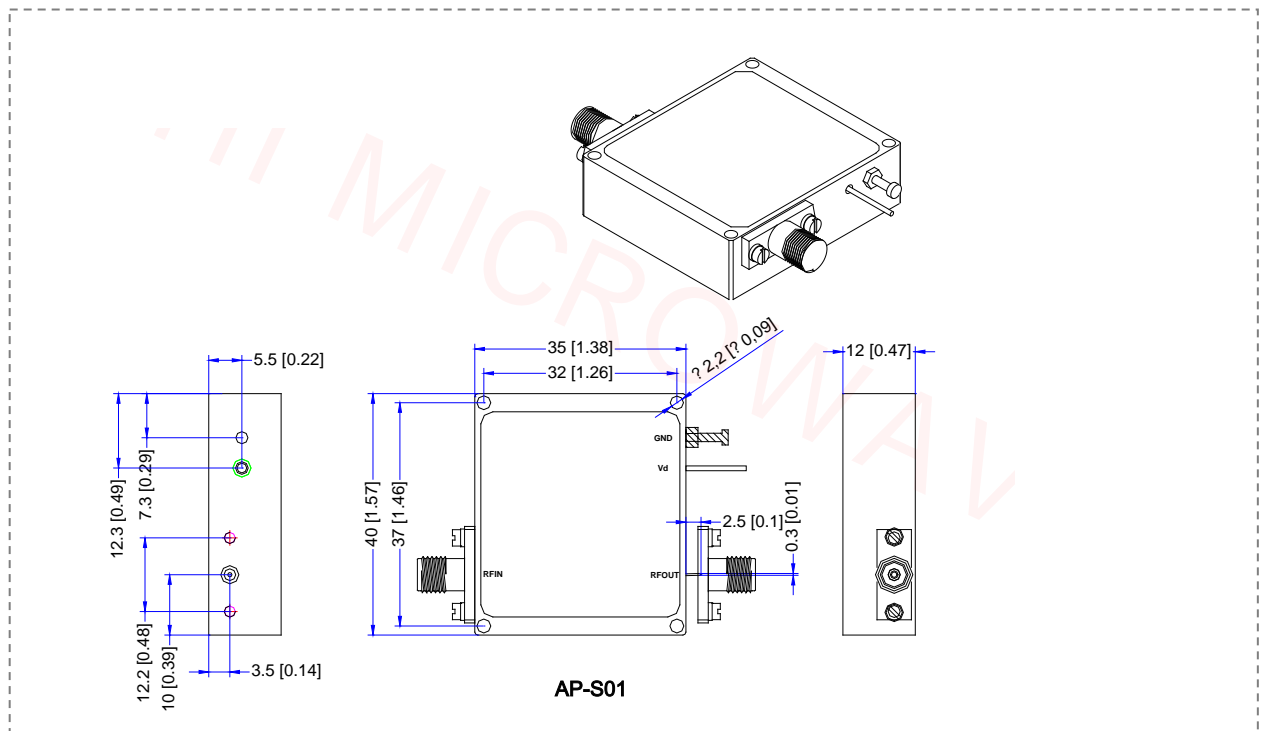

*****Heat Sink required during operation*****