

# MODEL HILNAT1403060

## 0.1-40GHz Low Noise Amplifier



Note: The photo is for illustration purposes only. Please refer to outline drawing

### ■ Features

- Ultra Wide Band: 0.1-40GHz
- Gain: 30dB
- Output Power: 20dBm
- High Output IP3: 30dBm

### ■ Applications

- Radar Systems
- Communication Systems
- Receivers Systems

### □ Electrical Specifications

Parameter	Min.	Typ.	Max	Units
Frequency Range	0.1-40			GHz
Gain	30	31		dB
Gain Flatness			±2.5	dB
Input VSWR		2		-
Output VSWR		2		-
Output Power for (P1dB)	18	19		dBm
Output Power Past		20		dBm
Noise Figure		6		dB
Output IP3		30		dBm
Input Max Power(no damage)			-5	dBm
DC Current (Vcc=+12V)		400		mA
Impedance	50			Ω
Input Output Connector	2.92-k			
Material	Aluminium\Gold Painting			
Weight	50g			
Package Sealing	General Sealing (Standard)			

### Environmental Conditions

Operational Temperature	-45°C~+85°C	Vibration	25g rms (15 degree 2KHz) endurance, 1 hour per axis
Storage Temperature	-55°C~+125°C	Shock	20G for 11msc half sin wave, 3 axis both directions
Executive Standard	MIL-STD-810G	Humidity	100% RH at 35c, 95%RH at 40°C

### Absolute Maximum Ratings

Supply Bias Voltage	+18V
RF INPUT POWER	-5dBm
ESD sensitivity (HBm)	Class 0, passed 150V



### Outline Drawing

All Dimensions in mm ( inches ) Tolerance  $\pm 0.25$  ( 0.01 )

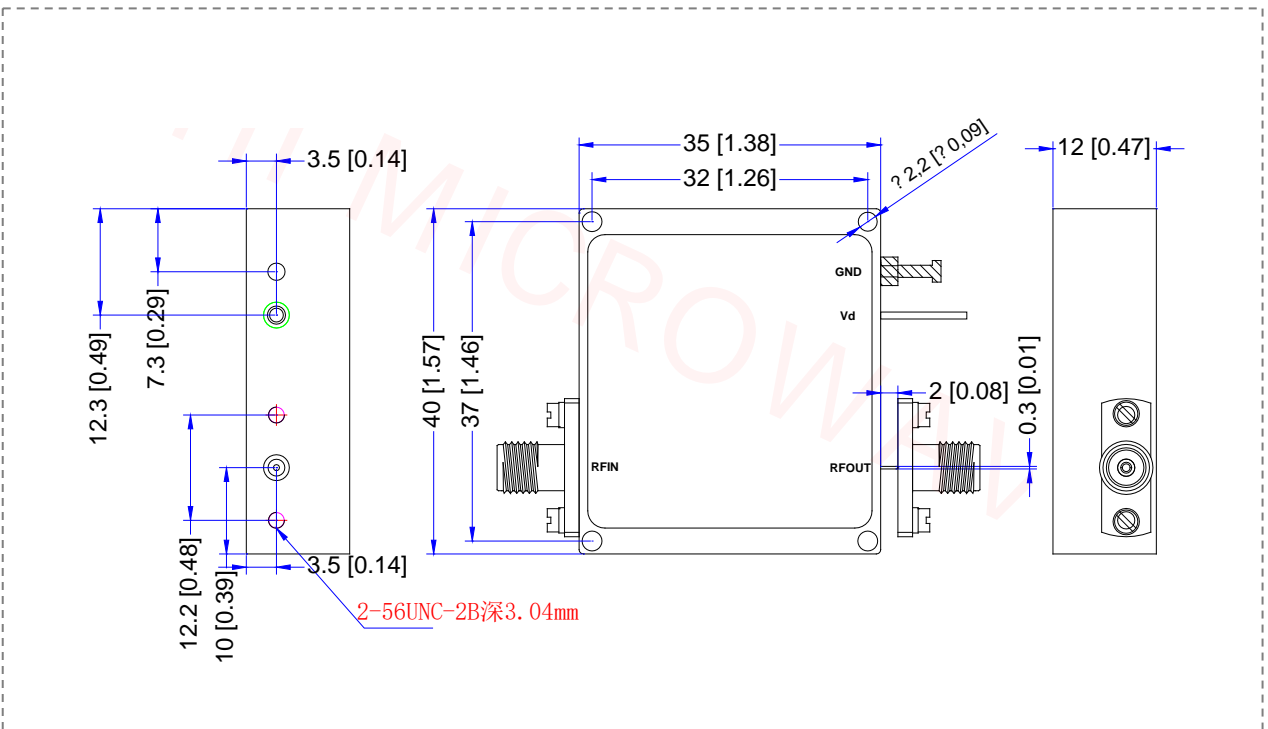

\*\*\*Heat Sink required during operation\*\*\*