

# MODEL HILNA02083508

## 2-8GHz Broadband Amplifier



Note: The photo is for illustration purposes only.  
Please refer to outline drawing

### ■ Features

- Ultra Broadband: 2~8GHz
- Low Noise Figure: 0.8dB
- High Gain: 35dB
- P1dB Output Power: 13dBm
- High OIP3: 25dBm
- Supply Voltage : +12V@ 100mA

### ■ Applications

- Radar Systems
- Communication Systems
- Receiving Systems

### □ Electrical Specifications

Parameter	Min.	Typ.	Max.	Units
Frequency Range	2-8			GHz
Gain	35	40		dB
Gain Flatness		±0.5	±1.3	dB
Input VSWR		1.6	2.0	-
Output VSWR		1.6	2.0	-
Output Power for 1 dB Compression (P1dB)	13	15		dBm
Output Power Psat		16		
Noise Figure		0.8	1.2	dB
OIP3		25		dBm
Input Max Power(no damage)			-5	dBm
DC Current (Vcc=+12V)		100	130	mA
Weight	50			g
Impedance	50			Ω
Input Connector	SMA-K(Removable)			
Output Connector	SMA-K(Removable)			
Material	Aluminum Gold Plating			
Package Sealing	General Sealing (Standard); Hermetically Seal(Optional)			

### Environmental Conditions

Operational Temperature	-45°C~+85°C	Vibration	25g rms (15 degree 2KHz) endurance, 1 hour per axis
Storage Temperature	-55°C~+125°C	Shock	20G for 11msc half sin wave,3 axis both directions
Executive Standard	MIL-STD-810G	Humidity	100% RH at 35c, 95%RH at 40°C

### Absolute Maximum Ratings

Supply Bias Voltage	+14V
RF INPUT POWER	-5dBm
ESD sensitivity (HBm)	Class 0, passed 150V



### Outline Drawing

All Dimensions in mm ( inches ) Tolerance  $\pm 0.25$  ( 0.01 )

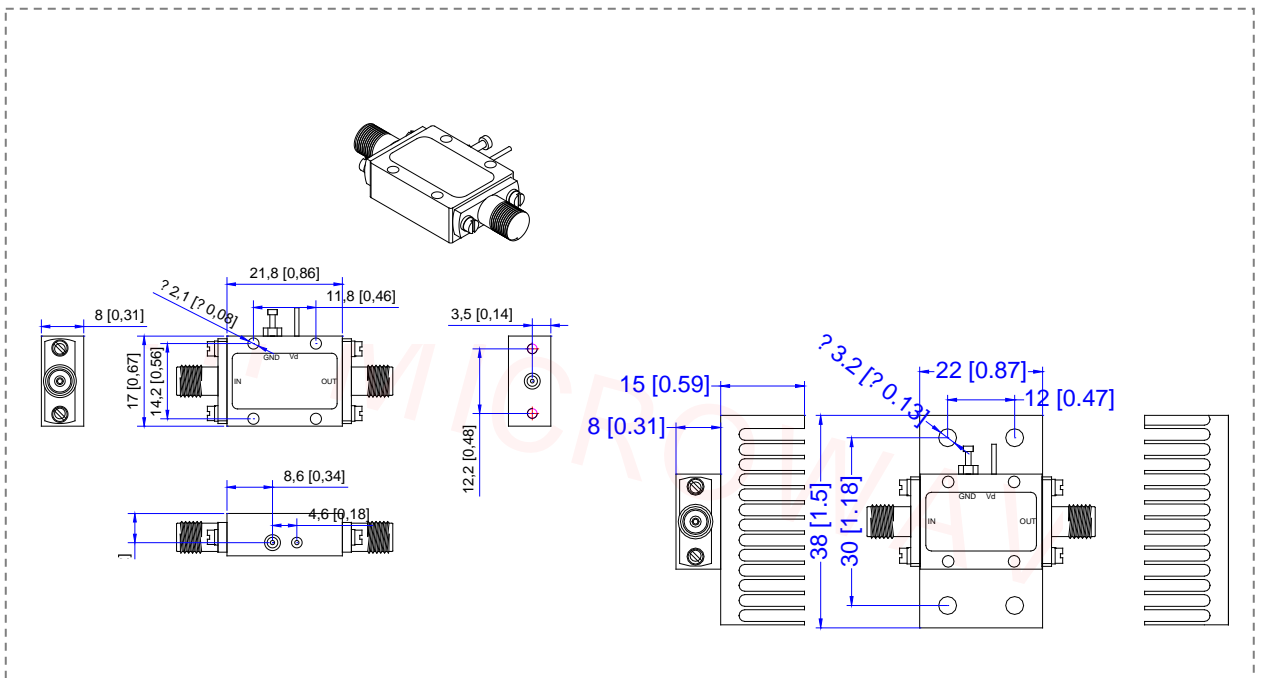

**\*\*\*Heat Sink required during operation\*\*\***