



Note: The photo is for illustration purposes only.
Please refer to outline drawing

■ Features

- Ultra Wide Band: 8-18GHz
- Gain: 30dB
- Output Power: 25dBm
- High Output IP3: 32dBm

■ Applications

- Radar Systems
- Communication Systems
- Receivers Systems

□ Electrical Specifications

Parameter	Min.	Typ.	Max	Units
Frequency Range	8~18			GHz
Gain	28		30	dB
Gain Flatness		±0.8	±1.0	dB
Input VSWR		1.4	1.6	
Output VSWR		1.4	1.6	
Output Power for 1 dB	22			dBm
Saturated Output Power (Psat)	25			dBm
Noise Figure			4	dB
OIP3	30	32		dBm
OIP2	40	42		dBm
Isolation	30			dB
Input Max Power(no damage)			+5	dBm
DC Current (Vcc=+12V)		400		mA
Impedance	50			Ω
Input Output Connector	SMA-k/SMA-K			
Material	Aluminium/Gold			
Weight	50g			
Package Sealing	General Sealing (Standard);			

Environmental Conditions

Operational Temperature	-45°C~+85°C	Vibration	25g rms (15 degree 2KHz) endurance, 1 hour per axis
Storage Temperature	-55°C~+125°C	Shock	20G for 11msc half sin wave, 3 axis both directions
Executive Standard	MIL-STD-810G	Humidity	100% RH at 35c, 95%RH at 40°C

Absolute Maximum Ratings

Supply Bias Voltage	15V
RF INPUT POWER	+5dBm
ESD sensitivity (HBm)	Class 0, passed 150V



OBSERVE PRECAUTIONS
ELECTROSTATIC SENSITIVE
DEVICES



Outline Drawing

All Dimensions in mm (inches) Tolerance ± 0.25 (0.01)

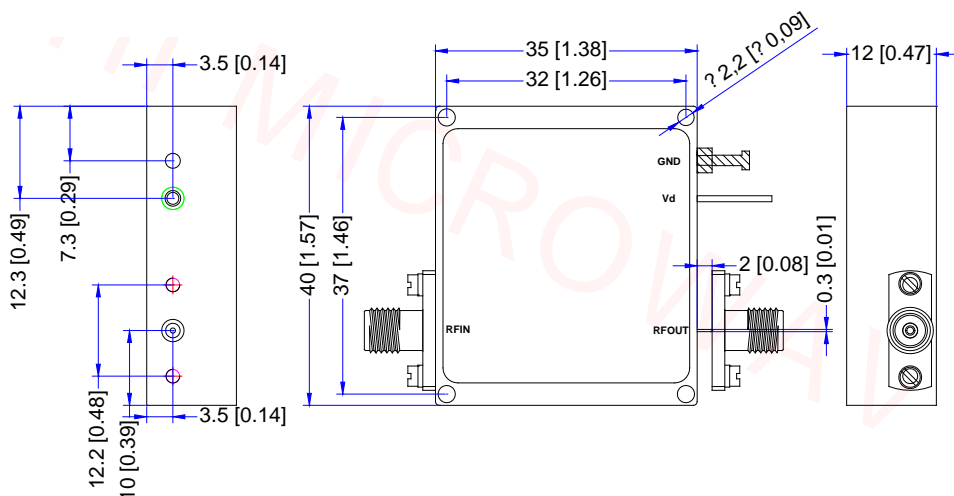

*****Heat Sink required during operation*****