



Note: The photo is for illustration purposes only.
Please refer to outline drawing

■ Features

- Ultra Wide Band: 9.5-10.5GHz
- Gain: 30dB
- Output Power: 25dBm
- High Output IP3: 35dBm

■ Applications

- Radar Systems
- Communication Systems
- Receivers Systems

□ Electrical Specifications

Parameter	Min.	Typ.	Max	Units
Frequency Range	9.5-10.5			GHz
Gain	30	31		dB
Gain Flatness		±0.3	±0.5	dB
Input VSWR		1.5	1.8	dB
Output VSWR		1.6	1.8	dB
Output Power for 1 dB Compression (P1dB)	25	27		dBm
Saturated Output Power (P _{sat})		28		dBm
Noise Figure		1.5	2.3	dB
Input Max Power(no damage)			20	dBm
DC Current (V _{cc} =+10~+15V)		300		mA
Impedance	50			Ω
Input Output Connector	SMA-k/SMA-K			
Material	Aluminium/Gold			
Weight	50g			
Package Sealing	General Sealing (Standard); Hermetically Seal(Optional)			

Environmental Conditions

Operational Temperature	-45°C~+85°C	Vibration	25g rms (15 degree 2KHz) endurance, 1 hour per axis
Storage Temperature	-55°C~+125°C	Shock	20G for 11msc half sin wave, 3 axis both directions
Executive Standard	MIL-STD-810G	Humidity	100% RH at 35c, 95%RH at 40°C

Absolute Maximum Ratings

Supply Bias Voltage	15V
RF INPUT POWER	20dBm
ESD sensitivity (HBm)	Class 0, passed 150V



OBSERVE
PRECAUTIONS
ELECTROSTATIC
SENSITIVE
DEVICES



Outline Drawing

All Dimensions in mm (inches) Tolerance ± 0.25 (0.01)

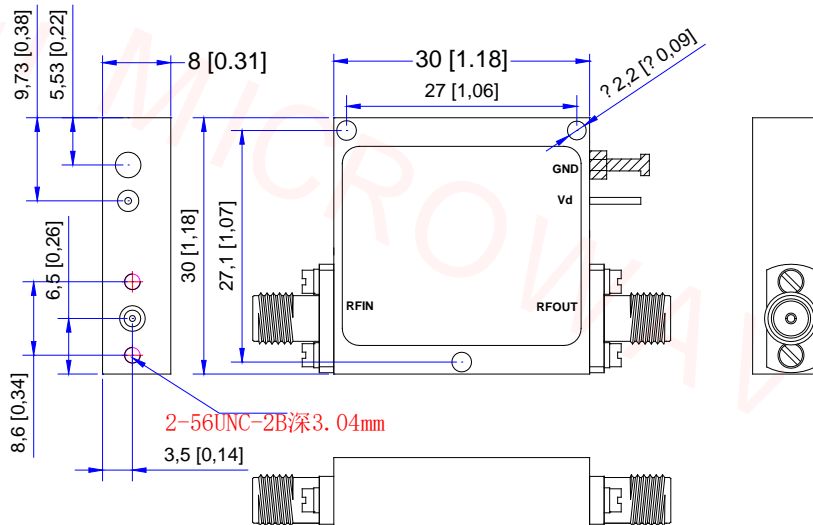

*****Heat Sink required during operation*****