



Note: The photo is for illustration purposes only.
Please refer to outline drawing

■ Features

- Ultra Wide Band: 18-40GHz
- Gain: 35dB
- Output Power: 20dBm
- High Output IP3: 30dBm

■ Applications

- Radar Systems
- Communication Systems
- Receivers Systems

□ Electrical Specifications

Parameter	Min.	Typ.	Max	Units
Frequency Range	18-40			GHz
Gain	35	40		dB
Gain Flatness		±2		dB
Input VSWR		2.0		dB
Output VSWR		2.0		dB
Output Power for 1 dB Compression (P1dB)	19	20		dBm
Saturated Output Power (Psat)	20	21		dBm
Noise Figure		5		dB
Input Max Power(no damage)			-10	dBm
DC Current (Vcc=+9~15V)		400		mA
Impedance	50			Ω
Input Output Connector	2.92			
Material	Aluminium/Gold Plated			
Weight	50g			
Size	40mmX35mmX12mm			
Package Sealing	General Sealing (Standard); Hermetically Seal(Optional)			

Environmental Conditions

Operational Temperature	-45°C~+85°C	Vibration	25g rms (15 degree 2KHz) endurance, 1 hour per axis
Storage Temperature	-55°C~+125°C	Shock	20G for 11msc half sin wave, 3 axis both directions
Executive Standard	MIL-STD-810G	Humidity	100% RH at 35c, 95%RH at 40°C

Absolute Maximum Ratings

Supply Bias Voltage	+15V
RF INPUT POWER	-10dBm
ESD sensitivity (HBm)	Class 0, passed 150V



Outline Drawing

All Dimensions in mm (inches) Tolerance ± 0.25 (0.01)

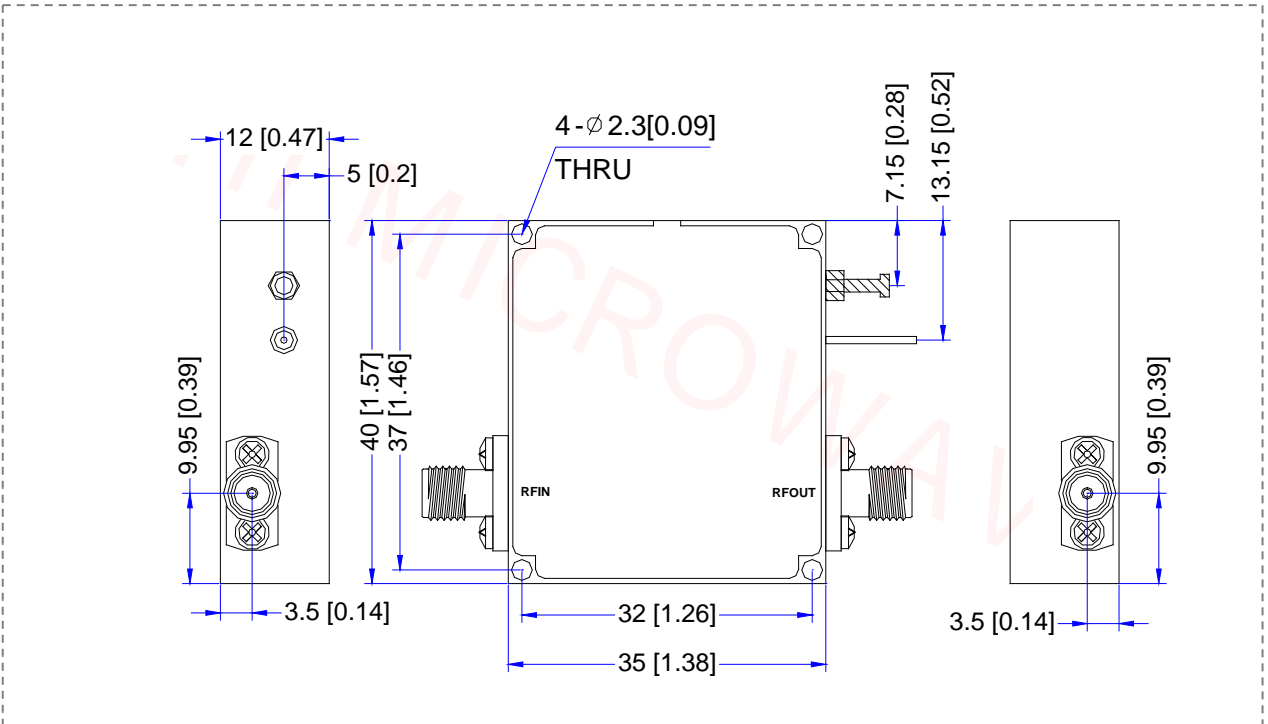

*****Heat Sink required during operation*****